

Accessories (options):

- Electronic Speed Controller Art.-No. 295
- Winch for
Drop Deck Semi-Trailer..... Art.-No. 443
- Electrical System Art.-No. 784
- Electrical System "MF-A" Art.-No. 797
- Supplementary Module for
servo operation Art.- No. 792
- 2 Allround Warning Lamps Art.- No. 793

For various other possibilities of outfit please find our suggestions and tips in the **WEDICO** catalog.

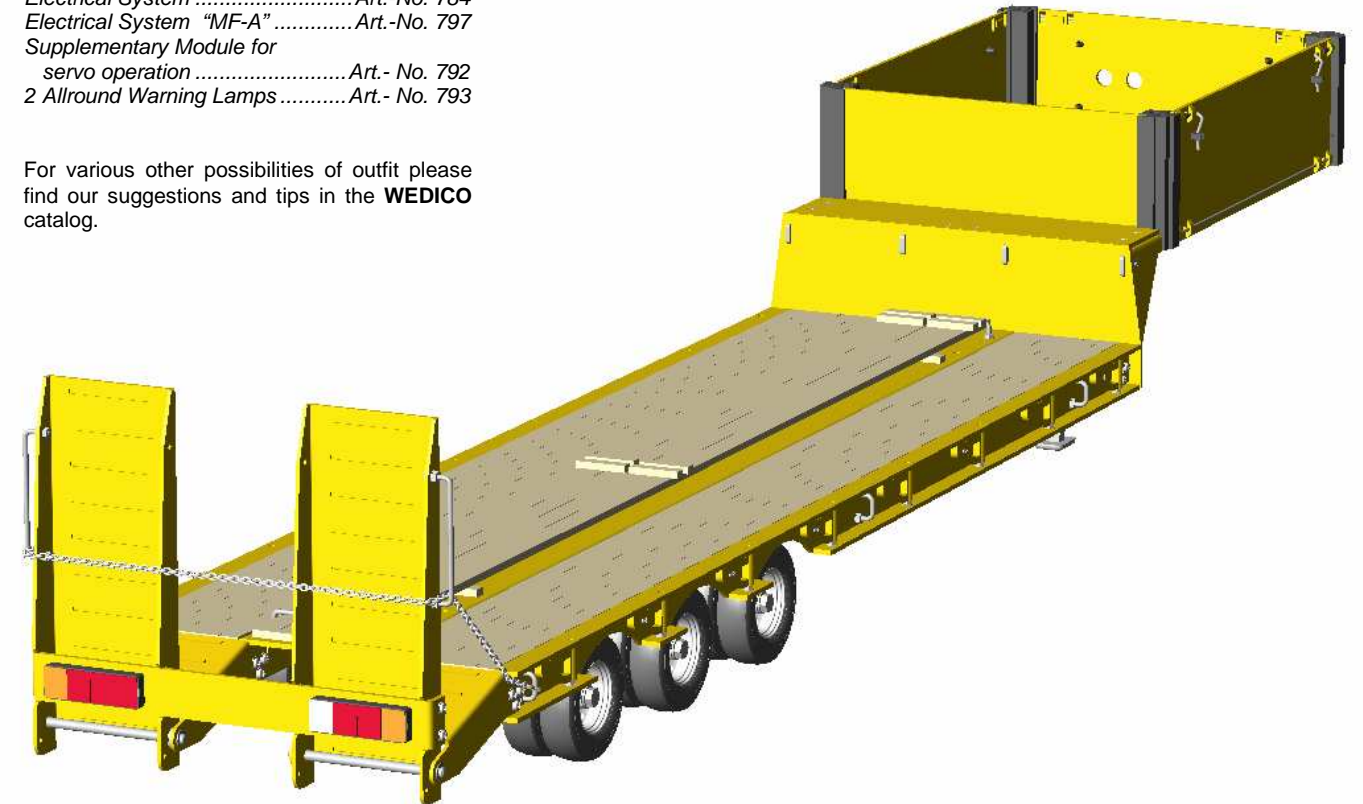

S-21-0

Complete list of parts necessary for the assembly (please use EDP-number when ordering spare parts)

Qty.	No.	Assembly part	EDP-No.	Qty.	No.	Assembly part	EDP-No.	Qty.	No.	Assembly part	EDP-No.
41	---	Nut M3	20040	1	315	Washer 3.2 large	22900	1	1216	Vertical panel	28498
6	2	Screw M3 x 8	20018	8	333	Screw M2 x 10	26902	2	1217	Trapezoidal panel, inside	28488
16	3	Screw M3 x 12	20022	2	341	Blinker lens, high, orange	20304	1	1218	Trapezoidal panel, outside, -lh-	28494
12	4	Screw M3 x 16	20024	4	342	Lens/rear light, high, red	20308	1	1219	Trapezoidal panel, outside, -rh-	28496
1	5	Screw M3 x 20	20224	16	360	Screw M2 x 20	30494	1	1220	Frame, rear side	28508
4	7	Countersunk screw M3 x 6	20028	1	398	Case with long hole	24432	1	1221	Cross member	28224
30	13	Washer 3.2	20046	1	399	Case without long hole	24434	12	1222	Lateral section, -lh-	28520
1	15	Serrated washer 3.2	20054	1	402	Shaft, double landing gear	24440	1	1223	Lateral section, -rh-	28522
6	17	Hex head screw M4 x 8	20036	1	403	Landing leg, double land- ing gear	24442	2	1224	Ramp, fix	28502
6	20	Washer 4.3	20048	1	438	Drop panel notched, yellow	28478	4	1225	Intermediate plate	28486
48	21	Tapping screw 2.2 x 4.5	20052	1	499	Drop panel long, yellow	28480	8	1226	Swivelling arm, -lh-	28516
82	24	Washer 2.2	21210	2	523	Grab bar, short	21206	8	1227	Swivelling arm, -rh-	28518
4	25	Retaining washer 3.2	20058	4	566	Shim 4 x 8 x 1	21998	16	1228	Pressure spring for swivelling arm	28270
12	26	Bushing 4 x 0.5 x 7	20088	2	643	Kingpin, metal fifthwheel	25388	6	1230	Lashing hook	28256
2	28	Threaded bushing 20mm	20070	1	647	Countersunk screw M3 x 16	25742	1	1231	Lamp support for 4-chamber lights	28484
6	33	Spring medium, "AF"	20134	1	657	Lamp chamber, 4-chamber light	25754	1	1232	Lamp support for standard round rear lamps	28482
6	34	Spring short, "AF"	20136	2	658	Frame, 4-chamber light	25756	2	1233	Ramp, mobile	28500
1	36	Steering linkage M2 x 50	20268	2	659	Reflector, 4-chamber light	25758	4	1234	Shim 4 x 8 x 0.3	24774
4	57	Screw M3 x 10	20020	2	660	Lens orange, 4-ch. light	25750	1	1235	Support for warning lamp	28258
2	65	Countersunk screw M3 x 12	20032	2	661	Lens red, 4-chamber light	25752	6	1236	Spring, long, 70mm	28254
3	68	Rear axle	20126	2	662	Lens clear, 4-ch. light	25748	6	1237	Axle bushing	28260
12	70	Spring carrier, plastic	20138	5	727	Countersunk tapping screw 2.2 x 6.5	26252	1	1238	Rear panel with out-cut for platform body	28490
2	73	Shaft for fifthwheel	20012	1	776	Countersunk screw M2 x 6	26248	1	1239	Rear panel without out- cut for platform body	28492
130	109	Nut M2	21208	4	789	Fork head	20400	12	1240	Wooden lane, 5 x 8 x 610	28448
60	114	Screw M2 x 6	21268	4	926	Countersunk screw M2 x 5	25224	4	1241	Board for lateral loading ramp 3 x 10 x 610	28450
4	115	Screw M2 x 8	21269	8	931	Hinge pin for drop panel, long	26974	12	1242	Cross wood, 3 x 5 x 22	28452
4	158	Corner stake for tarp-top, black	28464	2	1118	Case-cover -rh-	24436	2	1243	Clamping block, 3 x 5 x 50	28454
8	142	Stop sleeve (to be cut off the plastic tube 70mm)	20210	4	1119	Case-cover -lh-	24437	1	1244	Chain, 490mm	28474
4	169	Hook long -lh-	20578	1	1120	Hinge	24438	2	1245	S-hook 10mm	30434
4	170	Hook long -rh-	20580	1	1161	Tyre, Multitonn 245/70	28100				
1	176	Coil spring for lever	20260	6	1162	Rim small, grey	28214				
1	179	Carrier plate for kingpin	20186	12	1162	Rim small, chromed	28170				
1	180	Kingpin, standard fifthwheel	20188	6	1213	Frame, front side	28506				
1	248	Crank	22648	1	1214	Basic plate	28504				
2	253	Gear wheel 12 teeth, grey	25112	4	1215	Bracket	28252				
8	282	Fixing clip	20360								

Dear modelling enthusiast!

We are glad that you have decided on one of the precious **WEDICO** truck models! For the manufacture of individual parts **WEDICO** uses durable materials of high quality - rarely to find in these days. This guarantees durability and enjoyment of your model for years to come.

If you should ever require replacement parts, please get in touch with your dealer or directly with **WEDICO**. For order purpose it is important using not only those EDP-numbers mentioned within the general parts list but also indicating the necessary details concerning colour, quantity and exact term of the spares required. You may be assured that **WEDICO** will supply the replacement part as quick as possible.

Enjoy assembling your truck!

Your **WEDICO**-Team

Technical description

- Body** 1-2mm strong aluminium panel parts. High impact plastic components. Tyres made of soft rubber with reproduction of original tread pattern, chromed outside wheel rims. 3-part leaf spring packages made of stainless steel on all axles. Latch-type ramps with integrated bumper. Rear lights, alternatively for 4-chamber lights or standard round lamps. Double landing leg, adjustable of height. All individual parts are screwed. All models may be dismounted and reassembled again.
- Colour** Extremely hard epoxy powder coating. Excellent base when repainting for special purposes.
- Measurements** Length over all 937 mm
Width over all 178 mm
Height over all 170 mm
Loading height ca. 60 mm
Weight..... 2.3 kg

Screws, washers, etc. at scale 1:1

	M4 x 8 Part no. 17
	M3 x 20 Part no. 5
	M3 x 16 Part no. 4
	M3 x 12 Part no. 3
	M3 x 10 Part no. 57
	M3 x 8 Part no. 2
	M2 x 20 Part no. 360
	M2 x 10 Part no. 333
	M2 x 8 Part no. 115
	M2 x 6 Part no. 114
	Countersunk screw M3 x 16 Part no. 647
	Countersunk screw M3 x 12 Part no. 65
	Countersunk screw M3 x 6 Part no. 7
	Countersunk screw M2 x 6 Part no. 776
	Countersunk screw M2 x 5 Part no. 926
	Tapping screw 2.2 x 4.5 Part no. 21
	Counters. tapp. screw 2.2 x 6.5 Part no. 727
	Nut M3 ---
	Nut M2 Part no. 109
	Washer 4.3 Part no. 20
	Shim 4 x 8 x 0.3 Part no. 1234
	Shim 4 x 8 x 1 Part no. 566
	Washer 3.2 large Part no. 315
	Washer 3.2 Part no. 13
	Washer 2.2 Part no. 24
	Serrated washer 3.2 Part no. 15
	Retaining washer 3.2 Part no. 25

General notes

Please follow the steps of assembly accordingly to the instructions. Each single assembly step is described and illustrated; furthermore a **parts list** indicates the required components for the actual construction step. Carefully observe the notes explaining the various steps of assembly and use only those parts which are provided. This will insure a correct result of assembly.

M3 hex nuts are not provided with an identification number. For easier identification of different screws and washers, on the left side of this page we are adding an illustration of the **most important parts at original scale**.

Installation of an RC equipment

NOTE: For a wireless transmission of proportional pulses you will have to install the Electrical System „MF-A“, Art.-No. 797 (see below).

Electrical Installation

If you intend adding the lighting we recommend using the following articles :

- **Electrical System, Art.-No. 784**, so far your prime mover is equipped by an Electrical System of either Art.-No. 782 or No. 783.
- **Infrared System, Art.-No. 791** if your prime mover is equipped with one of the Electrical Systems of either Art.-No. 782, or No. 783 plus the Infrared Transmitter Art.-No. 790.
- **Electrical System „MF-A“, Art.-No. 797** if your prime mover is equipped with either the Electrical System „MF“, Art.-No. 796, or with one of the Electrical Systems of either Art.-No. 782 or No. 783 plus the Infrared Transmitter Art.-No. 790.

Tip: The make-up of this instruction allows putting together your own booklet if you wish so. For this purpose you have to fold and stick the pages as follows:

1. Turn round the **first page** with the **English text facing downwards**, and lay the **next page** on top of the first, with the **English text facing upwards**.
2. Glue the two pages together at the left outer edge (e.g. using adhesive tip) and fold the top page across to the left (with the fold vertically in the middle).
3. Lay the **next page** on top of the previous one with the **English text facing upwards**, stick the left outer edges and fold over to the left again as before. Similarly add the remaining pages.
4. Finally glue together all pages at the inner edges, too, and fold the **original page over as a cover**, sticking it firmly at the left hand edge.

1 Assembly of the gooseneck

On the drawing, the unit is shown from underneath.

Fix the frame **1213** underneath the basic plate **1214** using countersunk screws **776** and nuts **109**. Afterwards press both inner brackets **1215** into the vertical panel **1216**, set the vertical panel in front of the basic plate and slide the inner trapezoidal panels **1217** between frame and brackets. Then fix the trapezoidal panels as follows: at the rear with screw **57**, washer **13** and nut M3, at the front with countersunk screw **7** and nut M3. Now press both outer brackets **1215** into the vertical panel and slide the trapezoidal panel outside/lh **1218** and the trapezoidal panel outside/rh **1219** into the lower slots on the vertical panel. Fix the outer trapezoidal panels with each countersunk screw **7** and nut M3 onto the brackets, and with countersunk screws **776** and nuts **109** underneath the basic plate.

Assembly step 1

Qty.	No.	Assembly part
6	---	Nut M3
4	7	Countersunk screw M3 x 6
2	13	Washer 3.2
2	57	Screw M3 x 10
8	109	Nut M2
8	776	Countersunk screw M2 x 6
1	1213	Frame, front side
1	1214	Basic plate
4	1215	Bracket
1	1216	Vertical panel
2	1217	Trapezoidal panel, inside
1	1218	Trapezoidal panel, outside, -lh-
1	1219	Trapezoidal panel, outside, -rh-

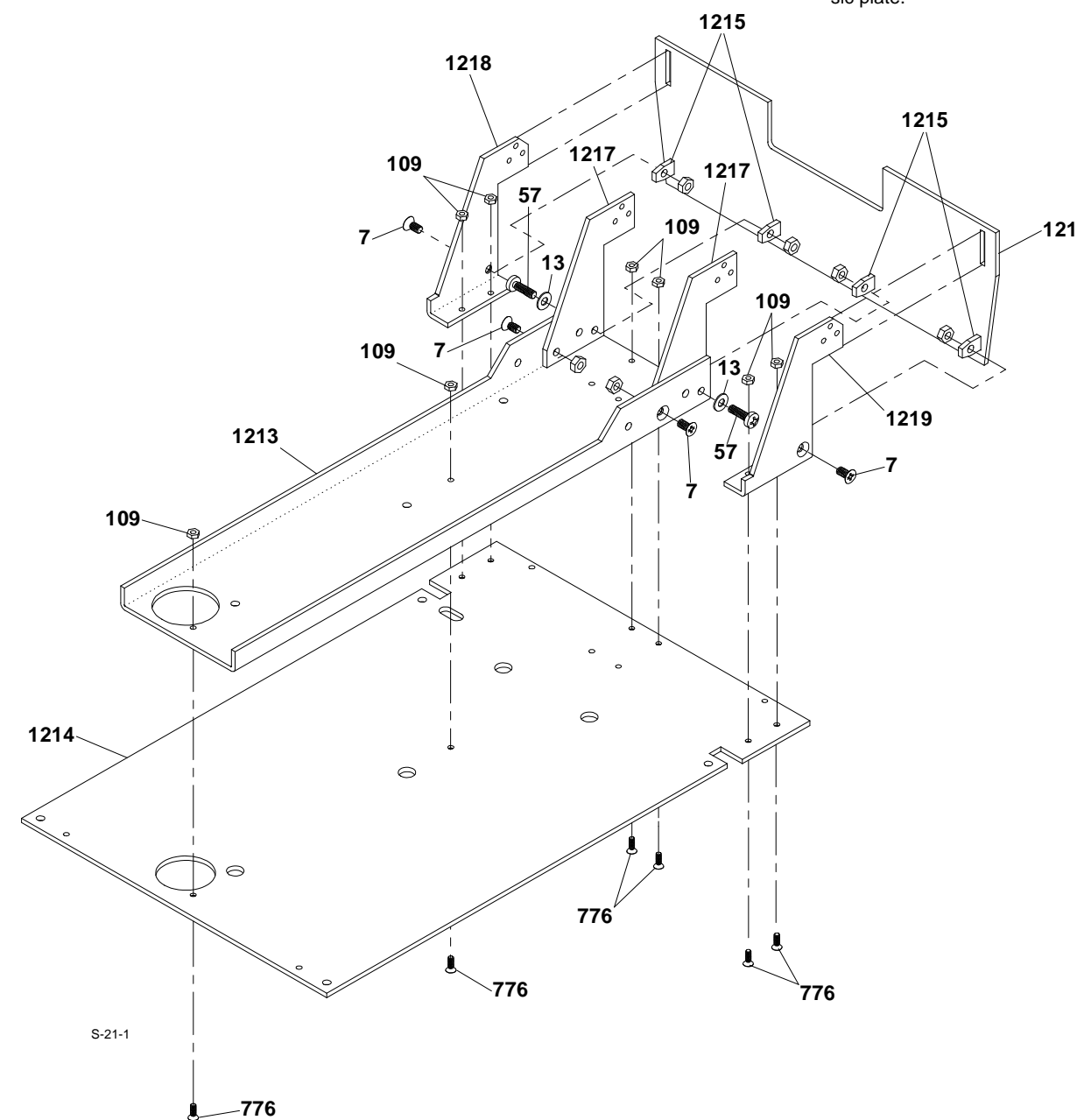

2 Mounting the drop base platform

On the illustration, the unit is shown from underneath.

Attach the front 5 cross members 1221 onto each side of the frame 1220 with screws 114, washers 24 and nuts M3. Then fix the left-hand lateral section 1222 and the right-hand lateral section 1223 onto the cross members; also for this purpose use screws 114, washers 24 and nuts 109.

Together with the rear cross members 1221 screw up each one ramp 1224 and two intermediate plates 1225 using screws 333, washers 24 and nuts 109. Additionally, for reasons of higher stabilisation, fix the ramp and the intermediate plates with screws 115, washers 24 and nuts 109.

Mount three lashing hooks 1230 on each side of the drop deck unit. The illustration shows how to fix the lashing hooks on the right-hand side. Fix the hooks as shown in the drawing; for this purpose use each one washer 24 and two nuts 109.

Set the assembled drop base platform in front of the prepared gooseneck. Slide the frame of the drop base between the vertical panel and the inner trapezoidal panels. Finally use screws 114, washers 24 and nuts M3 to attach frame and lateral sections onto the trapezoidal panels on the gooseneck.

Assembly step 2

Qty.	No.	Assembly part
70	24	Washer 2.2
76	109	Nut M2
52	114	Screw M2 x 6
4	115	Screw M2 x 8
8	333	Screw M2 x 10
1	1220	Frame, rear side
12	1221	Cross member
1	1222	Lateral section, -lh-
1	1223	Lateral section, -rh-
2	1224	Ramp, fix
4	1225	Intermediate plate
6	1230	Lashing hook

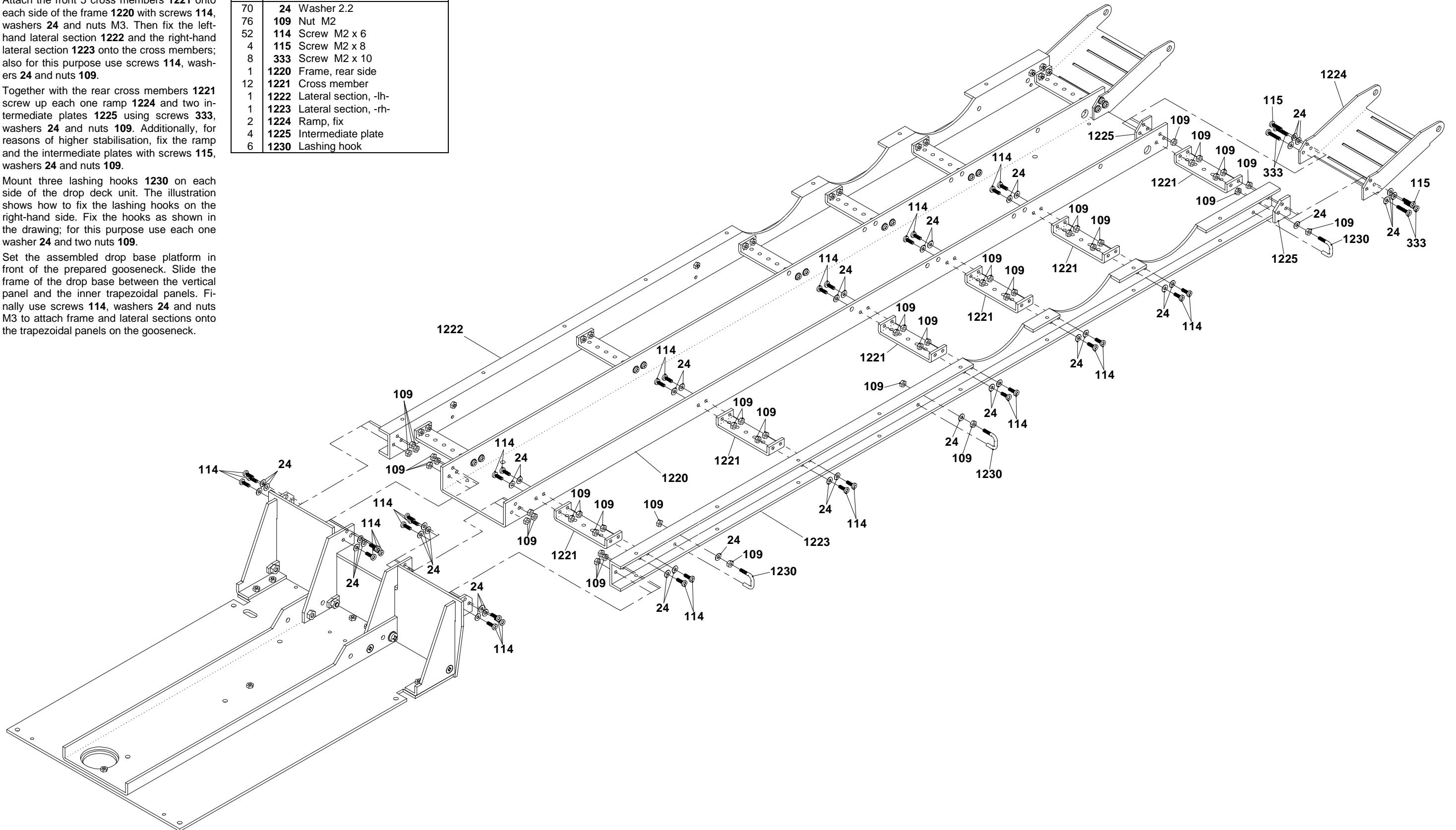

3 Attachment of landing leg and kingpin

3.1 Assembly of the landing leg

The crank 248 may be installed either on the right hand or on the left hand side. The position of the shaft depends on where the crank has been attached to since the thread end of the shaft must always face to the crank.

First set both case covers 1118 and 1119 onto the shaft 402. Slide then both gear wheels 253 that way onto the shaft, that the flattenings do correctly fit and sit flush with the shaft collar (see top right-hand drawing). Insert the shaft ends into the bores of the cases 398 and 399, then set the hinge 1120 as well as the spring 176 in place and screw the covers with screws 114 and nuts 109 onto the case.

Press now one nut M3 into the crank 248. Turn one nut M3 onto the thread of the shaft, add one serrated washer 15 and screw then the crank onto this thread. Tighten the nut behind the serrated washer towards the crank. From underneath insert now the landing gear 403.

☞ When lowering the landing gear the gear wheel will be released automatically by the hinge. For releasing the gear wheel when raising the landing gear slide the hinge upwards.

Mount the cases onto the frame of the gooseneck with screws 2, screws 57 and nuts M3.

3.2 Mounting the kingpin

Press one nut M3 into the hexagonal slot on the carrier plate 179 and screw up the kingpin. Depending on the type of fifthwheel you are using on your prime mover, use either screw 5 to mount the kingpin 180 provided for the standard fifthwheel, or use washer 315 and countersunk screw 647 to fix the kingpin 643 provided for the aluminium fifthwheel.

→ **When installing the Electrical System 784:** Lead now the coiled cable along the guide pins on the carrier plate.

With countersunk screws 65 and nuts M3 fix then the carrier plate underneath the frame.

Assembly step 3.1

Qty.	No.	Assembly part
6	---	Nut M3
2	2	Screw M3 x 8
1	15	Serrated washer 3.2
2	57	Screw M3 x 10
4	109	Nut M2
4	114	Screw M2 x 6
1	176	Coil spring for lever
1	248	Crank
2	253	Gear wheel 12 teeth, grey
1	398	Case with long hole
1	399	Case without long hole
1	402	Shaft, double landing gear
1	403	Landing leg, double land. gear
1	1118	Case-cover -rh-
1	1119	Case-cover -lh-
1	1120	Hinge

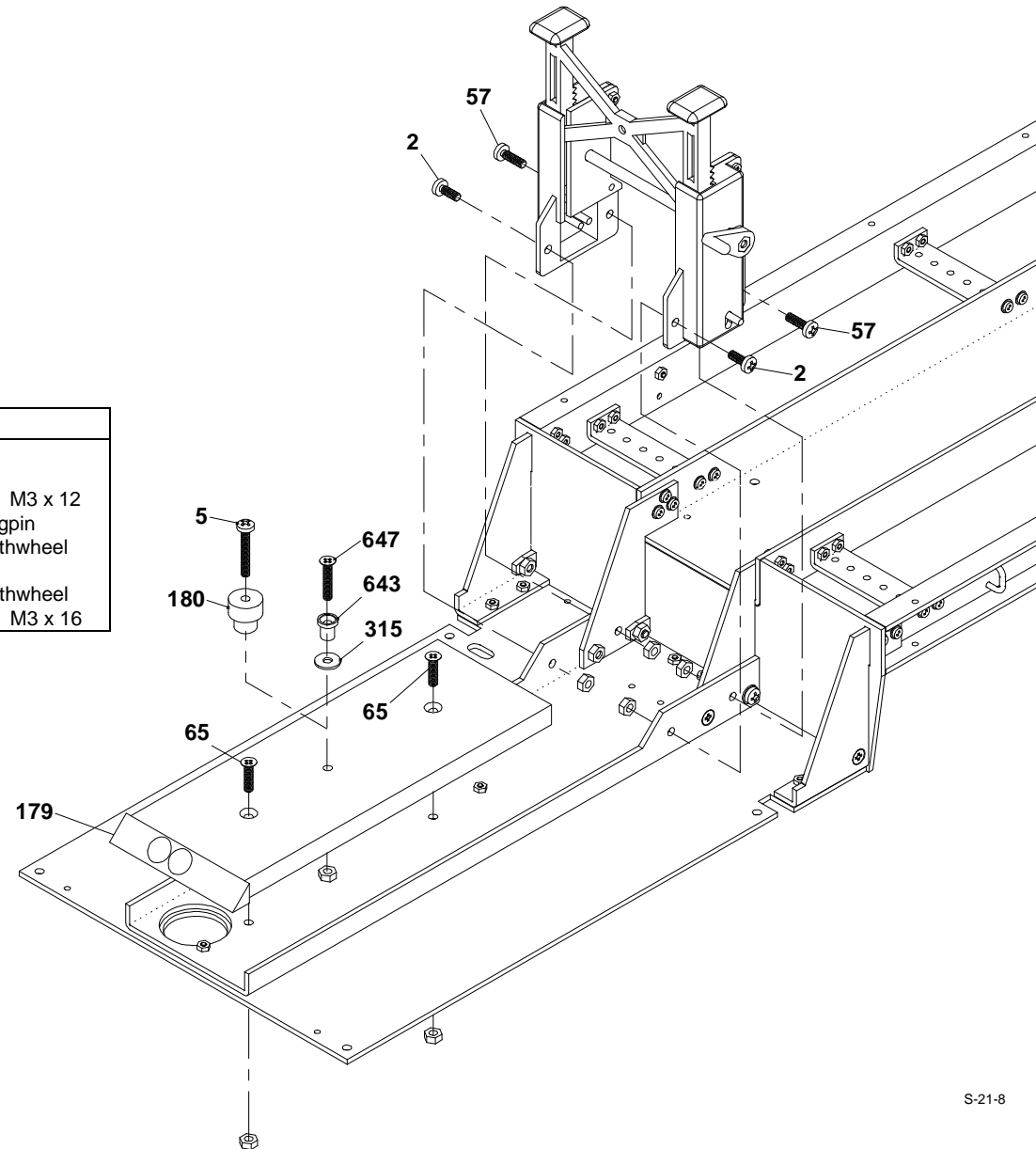
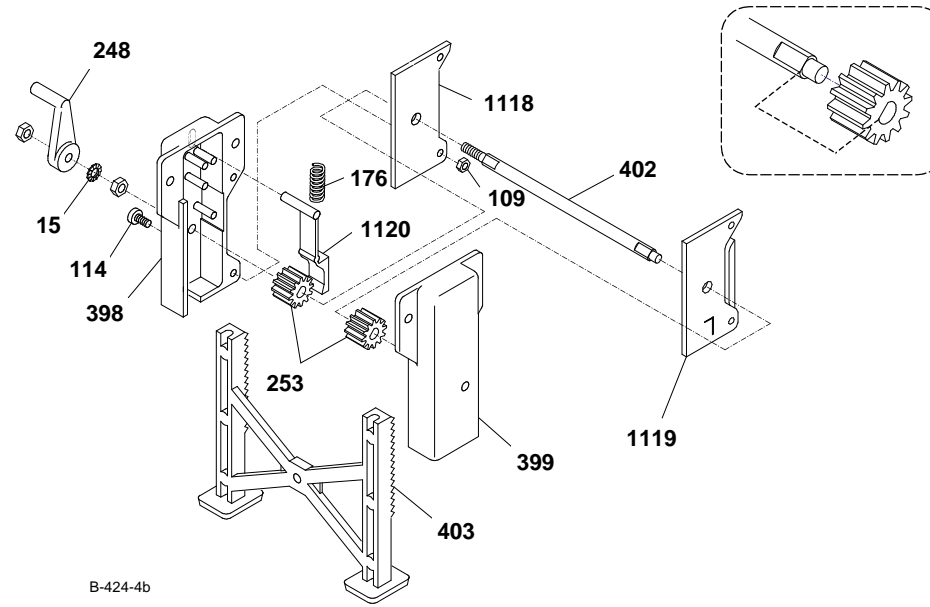

Assembly step 3.2

Qty.	No.	Assembly part
3	---	Nut M3
1	5	Screw M3 x 20
2	65	Countersunk screw M3 x 12
1	179	Carrier plate for kingpin
1	180	Kingpin standard fifthwheel
1	315	Washer 3.2 large
1	643	Kingpin for metal fifthwheel
1	647	Countersunk screw M3 x 16

4 Mounting the lamp supports

Assembly step 4

Qty.	No.	Assembly part
2	341	Blinker lens, high, orange
4	342	Lens/rear light, high, red
2	657	Lamp chamber, 4-ch. light
2	658	Frame, 4-chamber light
2	659	Reflector, 4-chamber light
2	660	Lens orange, 4-chamber light
5	661	Lens red, 4-chamber light
1	662	Lens clear, 4-chamber light
4	727	Countersunk tapping screw 2.2 x 6.5
1	1231	Lamp support for 4-chamber lights
1	1232	Lamp support for standard round rear lamp

→ **When installing an Electrical System:** First insert the bulbs in the lamp caps. When assembling take particular care that the bulb cables are not clamped; this could cause a short circuit!

→ **When installing the 4-chamber lights (Standard version):** Lay both frames 658 into the lamp support 1231 and screw them onto the light chambers 657 using screws 727. Then lay the reflectors 659 into the frames; accordingly to the drawing press now the lenses 660, 661 and 662 into the frames.

→ **Installation of standard round rear lamps (Option):** In this case use that lamp support 1232 supplied along with this kit. The necessary caps as well as the screws and nuts make part of the Electrical System Kits, Art.-No. 784 respect. 797.

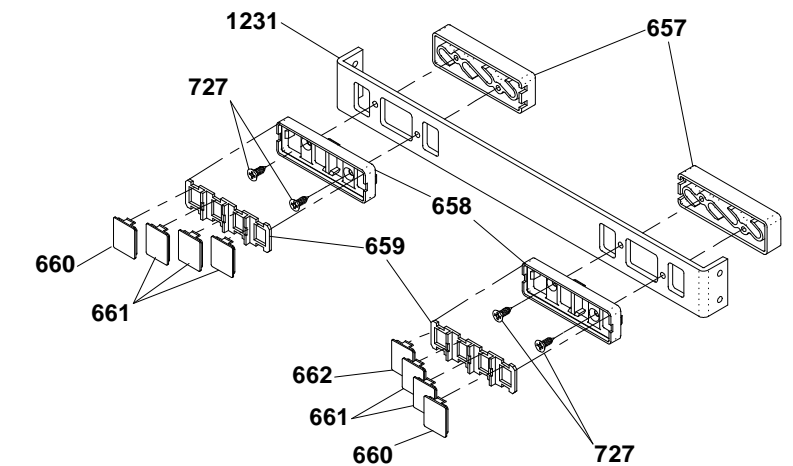

S-21-8

S-21-5

5 Mounting the ramps

Description is applied for the left-hand side; the attachment to the right-hand side has to be done similarly.

As shown in the illustration, use washers 24 and nuts 109 to fix one grab bar 523 onto the mobile ramp 1233. By shaft 73, now the mobile ramp becomes connected to the fixed ramp your previously have mounted. To the outside of the shaft between both ramps add a shim 1234; inside the shaft between both ramps add another shim 1234 plus a shim 566. Fix the shaft on both sides using a retaining washer 25.

→ **When installing all-round warnings, Art. No. 793** : In order to fix the support for the all-round warnings 1235 between the ramps, use screws 926 and nuts 109 which are supplied with this kit.

Afterwards set the completed lamp support behind the ramps and fix it with screws 114, washers 24 and nuts 109.

Assembly step 5

Qty.	No.	Assembly part
8	24	Washer 2.2
4	25	Retaining washer 3.2
2	73	Shaft for fifthwheel
16	109	Nut M2
4	114	Screw M2 x 6
2	523	Grab bar, short
2	566	Shim 4 x 8 x 1
4	926	Countersunk screw M2 x 5
2	1233	Ramp, mobile
4	1234	Shim 4 x 8 x 0.3
1	1235	Support for all-round warnings

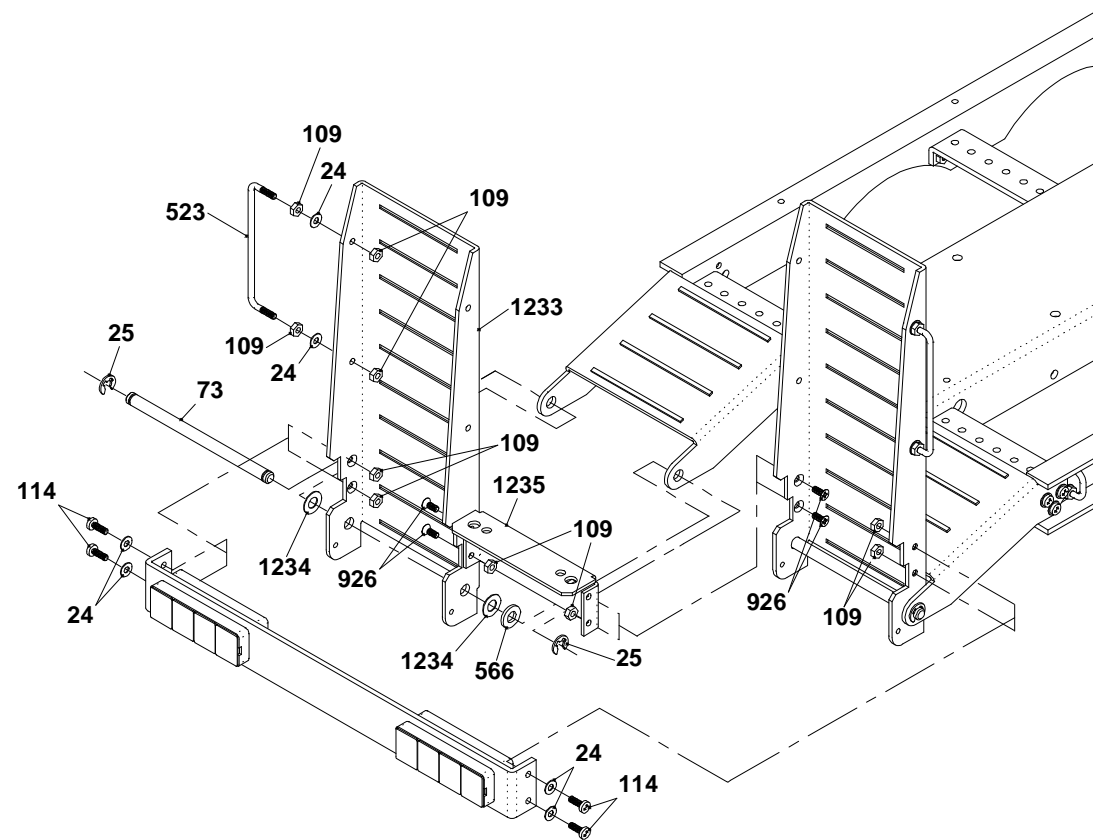

S-21-3

6 Assembly of the axles

The illustration shows the following positions: Assembly of the upper springs on the rear axle position, assembly of the lower springs with axle and wheels on the front axle position.

6.1 Assembly of the axles with suspension

First add the screws 3 together with washers 13, bushings 26, and M3 nuts to the rearward holes on the frame, provided for the attachment of the springs. Hang both long spring leaves 32 with their open ends to the bushing and use a screw 3, bushing 26, washer 13 and M3 nut to screw the closed ends to the frame. Press one each M3 nut into the hexagonal recess on the lower spring carrier 70. The axle 68 can now be mounted together with the spring carriers, one medium spring leaf 33 each, a short spring leaf 34 and screws 4 (see notes below).

⚠ Ensure that the sides of the spring carrier 70 marked by an "A" are mounted towards the wheel.

⚠ Mount the wheels accordingly to chapter 6.2 before you start tightening the screws 4. Please ensure that the spring sets are not under tension and can move freely.

Similarly assemble the fore and centre axle.

6.2 Mounting the wheels

⚠ Screw the wooden lanes onto the traverses accordingly to chapter 9 before you start mounting the wheels to the axles.

Once you have mounted the tyres 1161 onto the rims 1162, slide one each axle bushing 1237 onto the proper axle. Afterwards add the wheels onto the shaft whereby the vaults have to face towards each other, while the chromed rims are facing outwards; secure the unit with washer 20 and screw 17. The wheels should turn easily but there should not be too much play.

Assembly step 6.1

Qty.	No.	Assembly part
24	---	Washer 2.2
12	3	Screw M3 x 12
12	4	Screw M3 x 16
24	13	Washer 3.2
12	26	Bushing 4 x 0.5 x 7
6	33	Spring medium, "AF"
6	34	Spring short, "AF"
3	68	Rear axle 144mm
12	70	Spring carrier, plastic
6	1236	Spring, long, 70mm

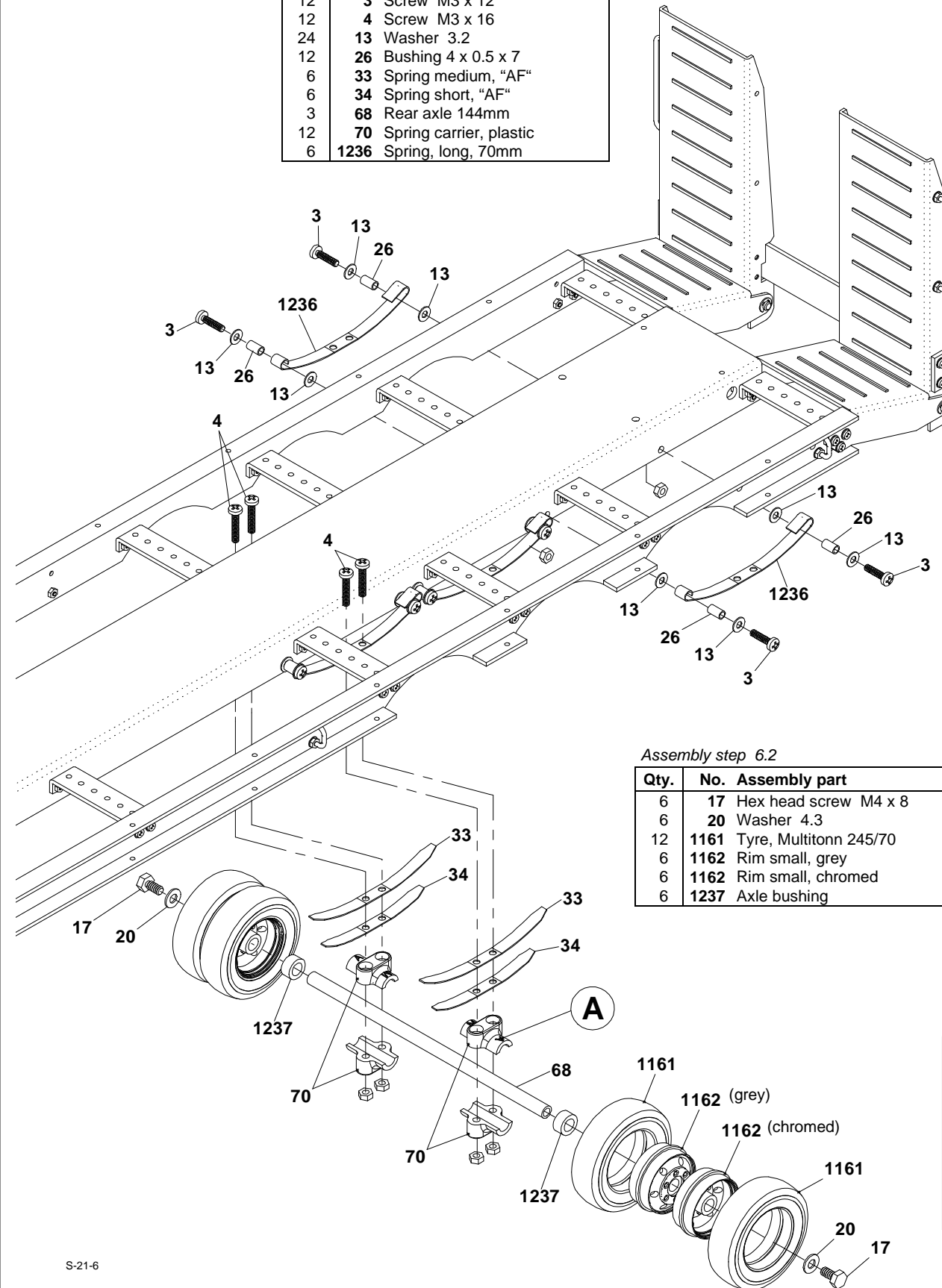

Assembly step 6.2

Qty.	No.	Assembly part
6	17	Hex head screw M4 x 8
6	20	Washer 4.3
12	1161	Tyre, Multitonn 245/70
6	1162	Rim small, grey
6	1162	Rim small, chromed
6	1237	Axle bushing

Tip!

Sometimes it happens that the chromed rims sit too tightly on the axle (work tolerance); in this case remove a bit the chrome inside the rims, and lightly grease the running surface (e.g. using Vaseline).

S-21-6

7 Installation of a servo operation for the ramps

7.1 Premounting the servo (not included in this kit)

Mount two screws **3** with washers **13** and nuts M3 onto the servo and afterwards turn the threaded bushing **28** onto the thread of the screws. Set the servo between frame and lateral section and fix it using screws **3** and washers **13**.

NOTE: For the servo operation of the ramps the following servos will fit (see data below mentioned):

Length x width x height: 40 x 20 x 38 mm
Torque: 30-40 Ncm
Gauge for screwing 45 ±1 mm

Use only servos including the so-called UNI-plugs.

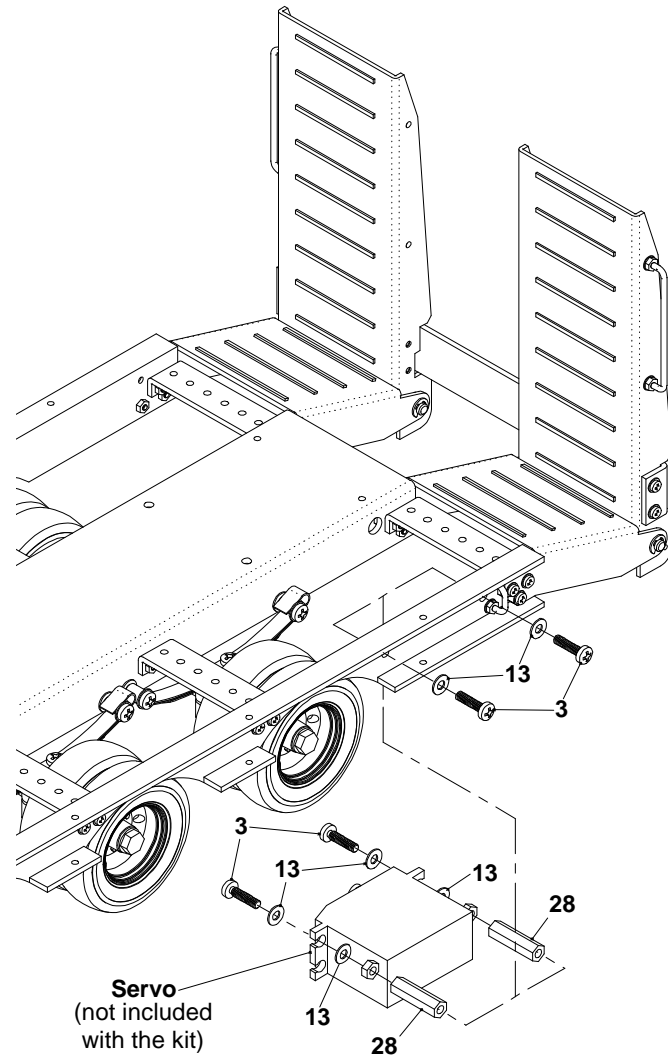

S-21-11

Assembly step 7

Qty.	No.	Assembly part
2	---	Nut M3
4	3	Screw M3 x 12
4	13	Washer 3.2
2	28	Threaded bushing 20mm
1	36	Threaded rod M2 x 50
2	109	Nut M2
2	789	Fork head

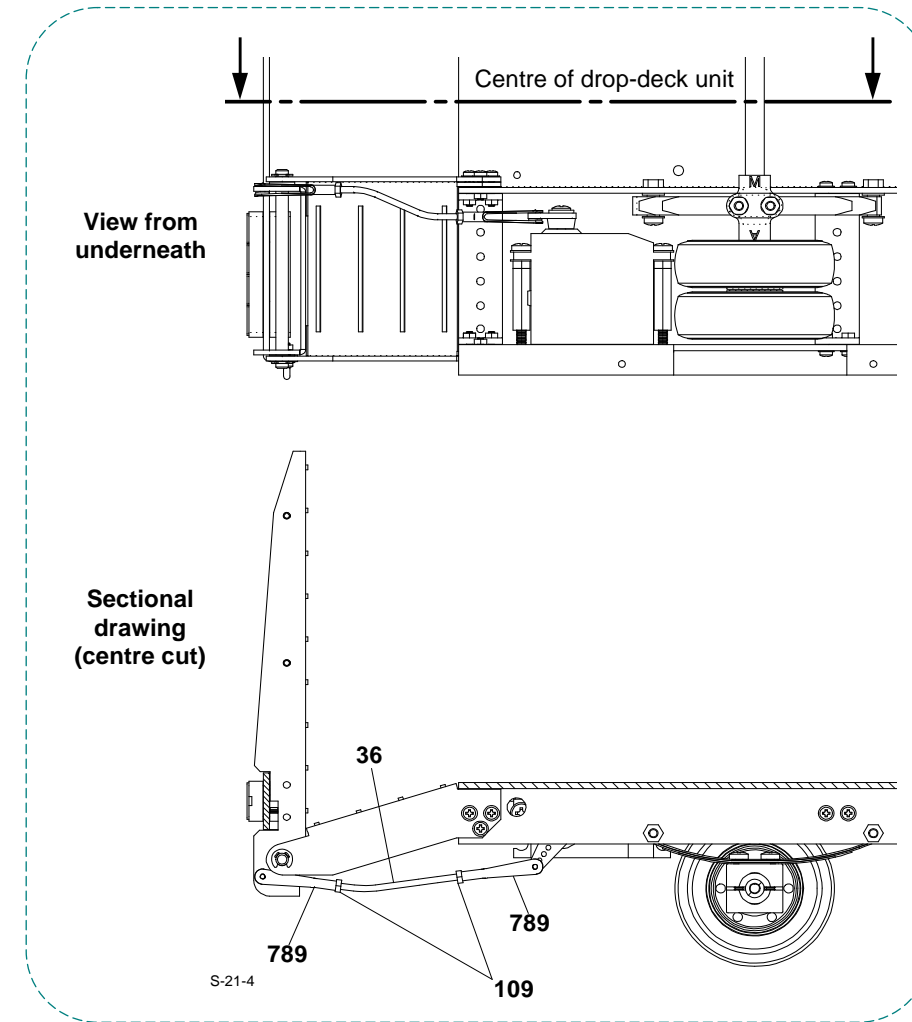

7.2 Adjustment of the servos

For operation of the servos, to the threaded rod **36** add two nuts **109** and two fork heads **789**. The threaded rod has lightly to be bent.

S-21-4

8 Preparing the lateral wooden boards

Using an appropriate glue (wood glue), stick each two of the boards **1241** to the long narrow sides. In order to glue the cross woods correctly, please refer to the true-to-scale drawing (below). Right- and left-hand side are identically mirror-inverted: Therefore and in sense of the drawing glue the cross woods **1242** as follows: For the left-hand side underneath, and for the right-hand side on top of the long boards.

Assembly step 8

Qty.	No.	Assembly part
4	1241	Board for lateral loading ramp, 3 x 10 x 610
12	1242	Cross wood, 3 x 5 x 22

S-21-10

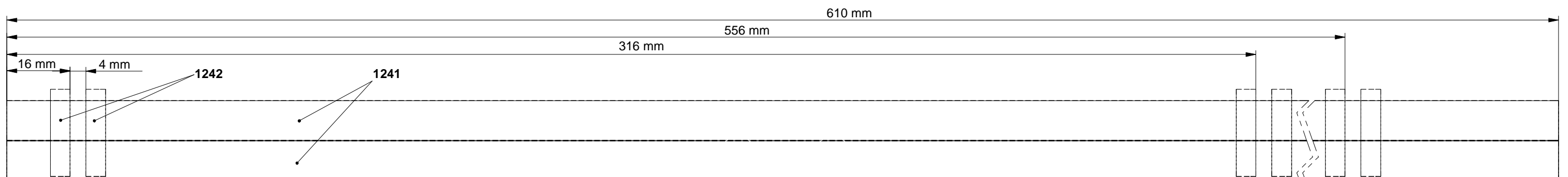

9 Completion of the drop base

Accordingly to the illustration, use screws **24** and nuts **109** to attach each one grab bar **523** to the front and the rear of the drop base frame.

For an easier differentiation of both swivelling arms **1226** and **1227** they are marked by letter „L“ (left-hand side), respectively by „R“ (right-hand side). At the right-hand front side, from underneath slide one screw **360** through the lower hole provided for the attachment on the lateral section. Put the following parts onto the screw thread, one-by-one: one nut **109**, one pressure spring **1228** and the swivelling arm **1227**. Once you have tightened the nut, the screw inside the upper hole of the lateral section gets fixed. Go ahead fixing the other swivelling arms similarly to the left-hand side: seven ones of **1227**, as well as eight arms **1226**.

If you do not intend adding a servo operation, you may also fix the ramps in vertical position using the chain supplied with this kit: Cut the chain **1244** to length and add an S-hook **1245** to each chain end. Lay the chain around the ramps and lead it through the lateral grab bars. Finally hang it into the rear lashing hooks.

Lay those wooden parts **1240** provided for the driving lane onto the cross members and fix them from underneath using screws **21**.

The glued and completed (see chapter 8) lateral wooden parts serve for widening the platform when laying them on the swivelling arms; as long as no widening is required lay them for savekeeping -upside down- underneath the grab bars on the centre frame. Fix them using both clamping blocks **1243** (no illustration) which have to be slid between frame and lateral wooden parts.

Assembly step 9

Qty.	No.	Assembly part
48	21	Tapping screw 2.2 x 4.5
4	24	Washer 2.2
24	109	Nut M2
16	360	Screw M2 x 20
2	523	Grab bar, short
8	1226	Swivelling arm, lh
8	1227	Swivelling arm, rh
16	1228	Pressure spring for swivelling arm
12	1240	Wooden lane, 5 x 8 x 610
2	1243	Clamping block, 3 x 5 x 50
1	1244	Chain, 490mm
2	1245	S-hook 10mm

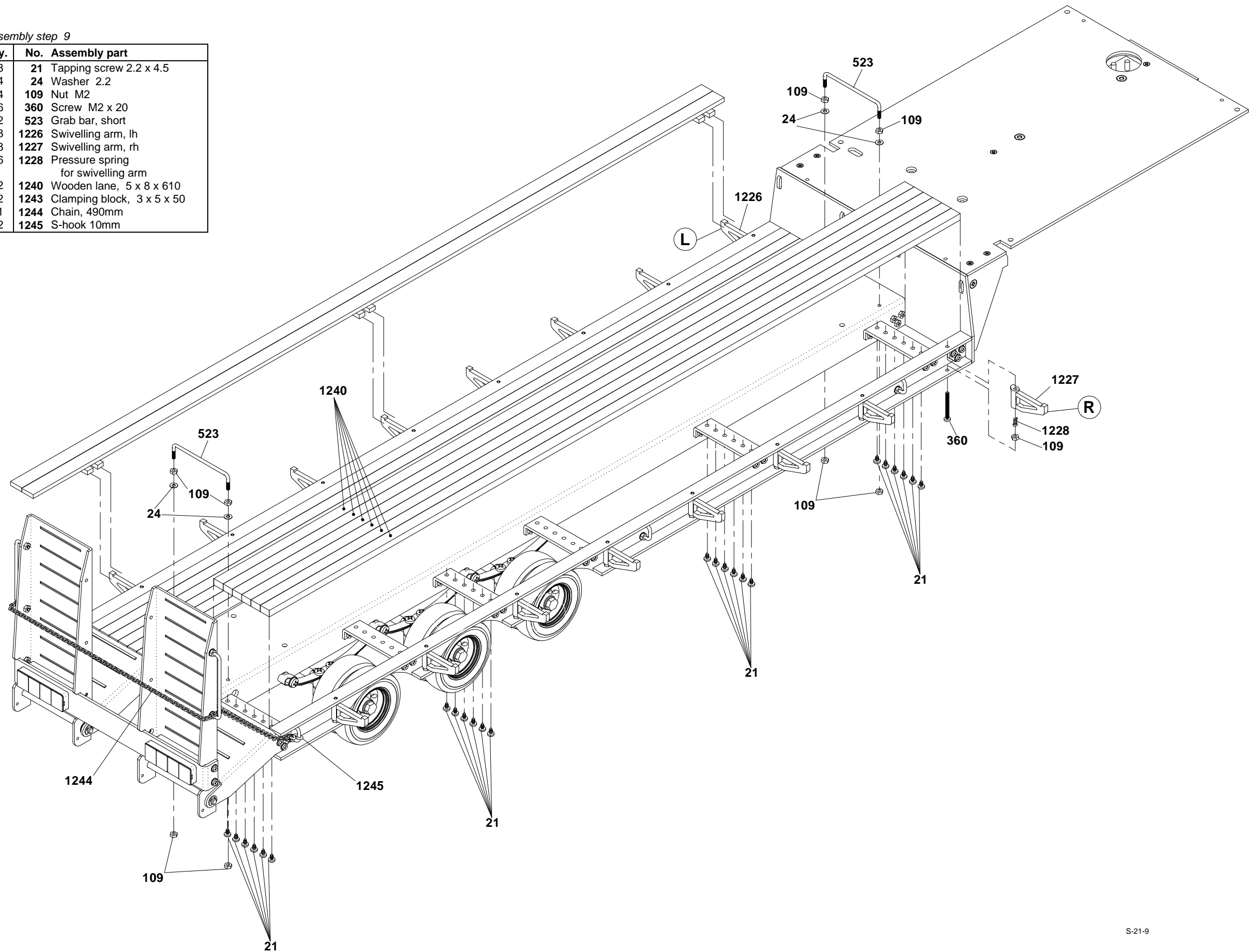

S-21-9

10 Assembly of the platform

10.1 Assembly of drop panel 438 with eyelet

From the attached plastic tube **142** cut off 4 stop sleeves, each of approx. 4 mm length. Accordingly to the enlarged illustration at the bottom slide one each of the hooks **169** and **170** into the lower eyelets on the drop panel **438**. In order to avoid a lateral gliding out of the hooks when opening the drop panels, add one stop sleeve between the pairs of eyelets on each drop side. To fix the hooks insert into the upper holes on the drop panel one each fixing clip **282**. The assembly of the upper hooks **169** and **170** has to be done by the same sense but turned by 180°.

Fix both fore corner stakes **158** with screws **2** onto the floor **1214**. Set the drop panel between the corner stakes; slide the lower hooks into those catching holes therefore provided and press them into the clips. The upper hooks serve to stop the drop panel; slide them into the lateral slots.

Assembly step 10.1

Qty.	No.	Assembly part
2	2	Screw M3 x 8
4	142	Stop sleeve (to be cut off the plastic tube 70mm)
2	158	Corner stake for tarp-top, black
2	169	Hook long -lh-
2	170	Hook long -rh-
4	282	Fixing clip
1	438	Drop panel notched

Assembly step 10.2

Qty.	No.	Assembly part
2	2	Screw M3 x 8
4	142	Stop sleeve (to be cut off the plastic tube 70mm)
2	158	Corner stake for tarp-top, black
2	169	Hook long -lh-
2	170	Hook long -rh-
4	282	Fixing clip
2	499	Drop panel long
2	931	Hinge pin for drop panel, long
1	1238	Rear panel with cut-out for platform unit
1	1239	Rear panel without out-cut for platform unit

10.2 Assembly of drop panels 499 with hinge pins

From the attached plastic tube cut off further 4 stop sleeves **142**. For the assembly of the upper hooks **169** and **170**, please refer to chapter 10.1.

Then insert one hinge pin **931** (see enlarged drawing at the right-hand side of this page) through the lower eyelets of the drop panel **499** for the left side and set the drop panel behind the premounted corner stake. Behind this unit add a corner stake **158** and fix it onto the floor using screw **2**. Mount then the drop panel for the right side in the same manner.

Finally slide the rear panel **1239** between the rear corner sections into place.

→ **When installing a Cable Winch, Art.-No. 443:** In this case please use that rear panel with cut-out **1238** which is supplied with this kit.

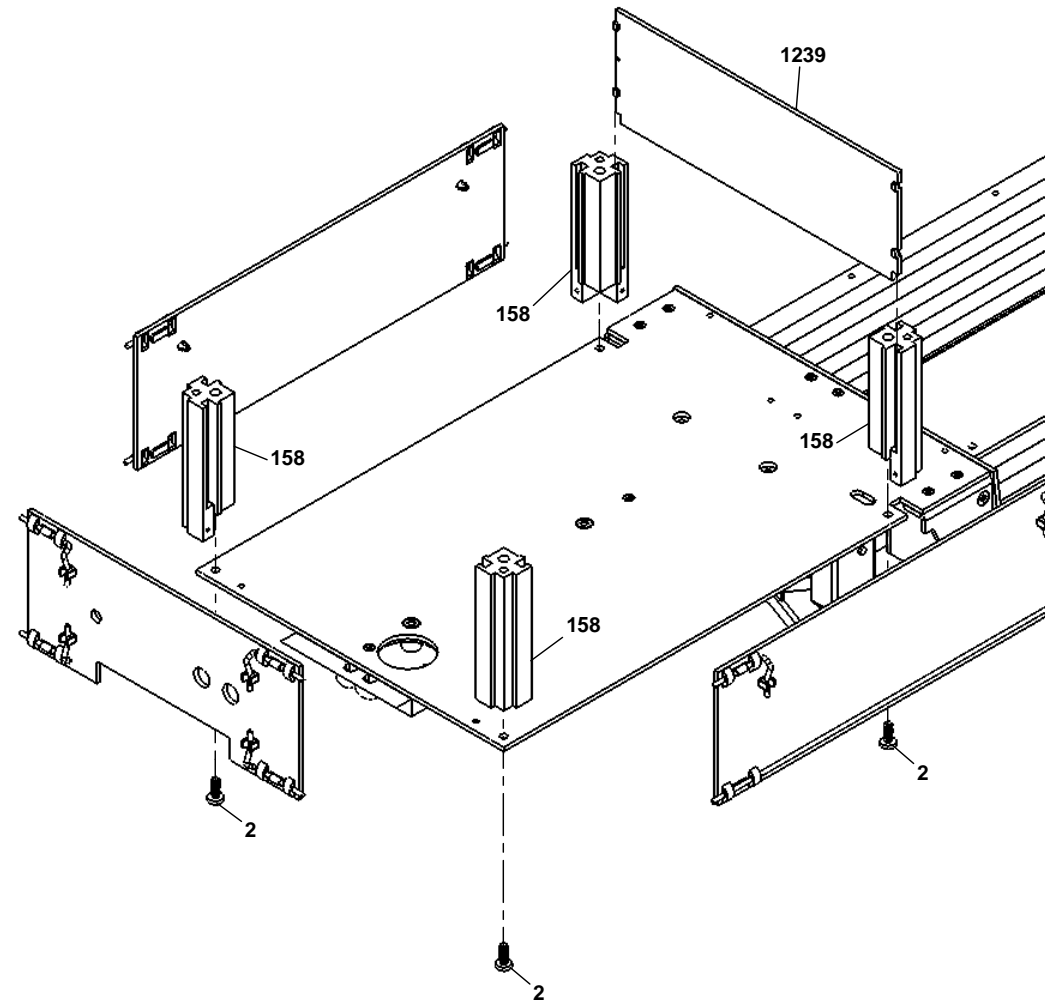

Drop panel 438

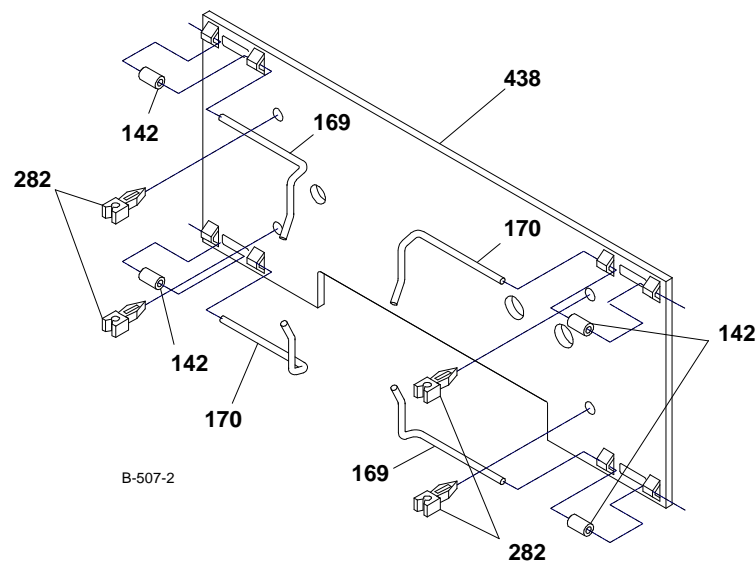

Drop panel 499

