

14+
AGES

Bedienungsanleitung - Instruction Manual

Artikel | Item: 22415

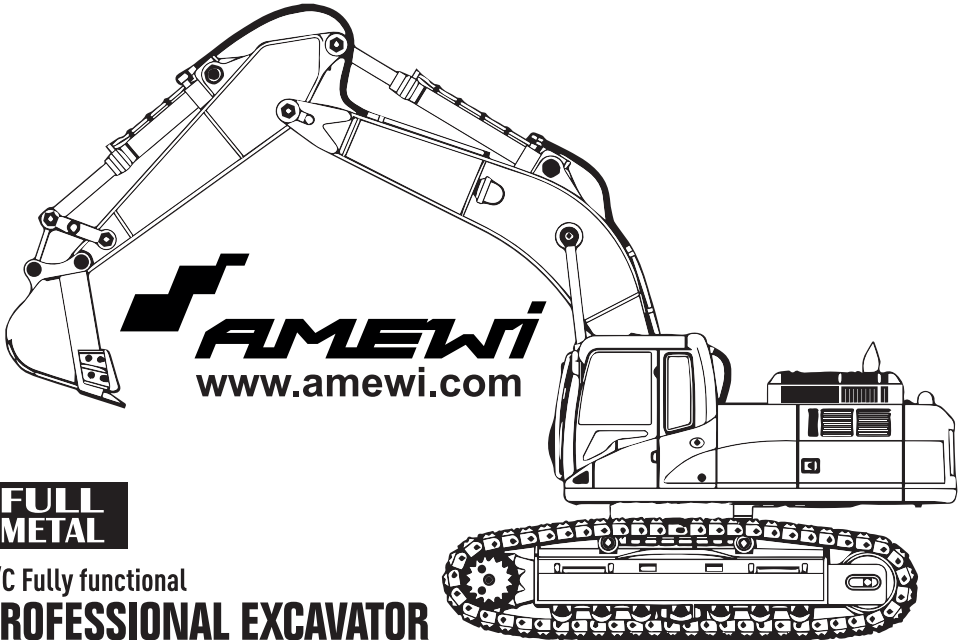

**FULL
METAL**

R/C Fully functional

PROFESSIONAL EXCAVATOR



AMEWI Trade e.K. Nikolaus-Otto-Str.18 33178 Borcheln Germany
www.amewi.com info@amewi.com



<https://www.facebook.com/amewicom/>



Herzlich willkommen

AMEWI TRADE e.K. ist ein junges, international tätiges Import- und Großhandelsunternehmen im Bereich RC Modellbau und Spielwaren, mit Sitz in Borcheln bei Paderborn.

Unsere Produktpalette beinhaltet über 6.000 Artikel.

Dazu gehören vor allem ferngesteuerte Auto-, Hubschrauber-, Boots- und Panzermodelle sowie ein reichhaltiges Zubehör und alle erforderlichen Ersatzteile. Unser Vertriebsnetz umfasst europaweit über 600 Fach- und Onlinehändlern.



Die Firma AMEWI Trade e.K. ist ein reines Großhandelsunternehmen.
Wir vertreiben unsere Produkte ausschließlich an Einzelhändler.

Wenn Sie als Endverbraucher AMEWI-Produkte erwerben, gehen Sie einen Vertrag mit dem Einzelhändler ein.

Wenden Sie sich bitte bei Gewährleistungsfällen immer an Ihren Händler.

Dieses Fahrzeug ist kein Spielzeug. Es ist nicht für Personen unter 14 Jahren geeignet. Lesen Sie die Anleitung aufmerksam und suchen Sie als Anfänger die Hilfe eines erfahrenen RC Car Piloten.

Das Modell und Zubehör muss vor Kindern unter 3 Jahren ferngehalten werden. Einzelteile können verschluckt werden und führen so zu einer Erstickungsgefahr.

Hinweise zur Konformität

Dieses Modell wurde nach dem derzeit aktuellen Stand der Technik gefertigt. Das Produkt erfüllt die Anforderungen der geltenden europäischen und nationalen Richtlinien. Die CE-Konformität wurde nachgewiesen. Die Firma AMEWI Trade e.K. erklärt hiermit, dass dieses Produkt den grundlegenden Anforderungen und den übrigen einschlägigen Bestimmungen der Richtlinie 2014/53/EU (RED) entspricht.

Den vollständigen Text der Konformitätserklärung finden Sie unter: <https://amewi.com/de/downloads/index/search/>

Weitere Fragen zum Produkt und zur Konformität richten Sie bitte an:

AMEWI Trade e.K., Nikolaus-Otto-Str. 18, 33178 Borcheln, Fax: +49 (0)5251 / 288965-19, Email: info@amewi.com.



Sicherheits- und Gefahrenhinweise



Achtung! Bei Schäden, die durch Nichtbeachten dieser Bedienungsanleitung verursacht werden, erlischt der Anspruch auf Gewährleistung! Für Folgeschäden übernehmen wir keine Haftung! Bei Sach- oder Personenschäden, die durch unsachgemäße Handhabung oder Nichtbeachten der Sicherheitshinweise verursacht werden, übernehmen wir keine Haftung!

Achtung! Aus Sicherheits- und Zulassungsgründen (CE) ist das eigenmächtige Umbauen und/oder Verändern des Gerätes nicht gestattet. Zerlegen Sie es das Modell nicht.

Achtung! Kleinteile. Erstickungs- oder Verletzungsgefahr durch Kleinteile.

Achtung! Das Produkt ist kein Spielzeug und nicht für Personen unter 14 Jahren geeignet!

Das Produkt darf nicht feucht oder nass werden.



Das Fahrzeug darf nur auf glatten, ebenen und sauberen Flächen verwendet werden.

Durch Herunterfallen aus bereits geringer Höhe wird das Produkt beschädigt.

Der gleichzeitige Betrieb von Fahrzeugen der gleichen Sende-/Empfangsfrequenz ist nicht möglich, da sich diese gegenseitig beeinflussen.

Hinweise zu Batterien / Hinweise zur Batterieentsorgung



Achtung! Batterien / Akkus gehören nicht in Kinderhände.

Ein Wechsel der Batterien oder Akkus ist nur durch einen Erwachsenen durchzuführen. Niemals wiederaufladbare Akkus mit Trockenbatterien mischen. Niemals volle mit halbleeren Akkus/Batterien mischen. Niemals Akkus verschiedener Kapazität mischen. Versuchen Sie niemals Trockenbatterien zu laden. Achten Sie auf die richtige Polarität. Defekte Akkus/Batterien sollten ordnungsgemäß (Sondermüll) entsorgt werden. Den Ladevorgang niemals unbeaufsichtigt durchführen. Bei Fragen zur Ladezeit lesen Sie die Bedienungsanleitung oder wenden Sie sich an den Hersteller.

Entsorgungshinweise



Die Firma AMEWI ist unter der WEEE Reg. Nr. DE93834722 bei der Stiftung EAR angemeldet und recycelt alle gebrauchten elektronischen Bauteile ordnungsgemäß. Elektrische und elektronische Geräte dürfen nicht in den Hausmüll! Entsorgen Sie das Produkt am Ende seiner Lebensdauer gemäß den geltenden gesetzlichen Vorschriften. Sie als Endverbraucher sind gesetzlich (Batterieverordnung) zur Rückgabe aller gebrauchten Batterien und Akkus verpflichtet, eine Entsorgung über den Hausmüll ist untersagt!

Schadstoffhaltige Batterien/Akkus sind mit nebenstehenden Symbolen gekennzeichnet, die auf das Verbot der Entsorgung über den Hausmüll hinweisen. Die zusätzlichen Bezeichnungen für das ausschlaggebende Schwermetall sind: Cd=Cadmium, Hg=Quecksilber, Pb=Blei (Bezeichnung steht auf Batterie/Akku z.B. unter den links abgebildeten Mülltonnen-Symbolen).



Durch die RoHS Kennzeichnung bestätigt der Hersteller, dass alle Grenzwerte bei der Herstellung beachtet wurden.



Mit dem Recyclingsymbol gekennzeichneten Batterien können Sie in jedem Altbatterie-Sammelbehälter (bei den meisten Supermärkten an der Kasse) entsorgen. Sie dürfen nicht in den Rest- bzw. Hausmüll.



Die Firma AMEWI Trade e.K. beteiligt sich am Dualen System für Verkaufsverpackungen über die Firma Landbell AG. Die verwendeten Verpackungen werden von Partner-Unternehmen (Entsorgern) bei den privaten Endverbraucher (Haushalten, „Gelber Sack“, „Gelbe Tonne“) abgeholt, sortiert und ordnungsgemäß verwertet. Die Teilnahme an einem Dualen System trägt zur CO₂-Einsparung teil.

Funktionen Fernbedienung

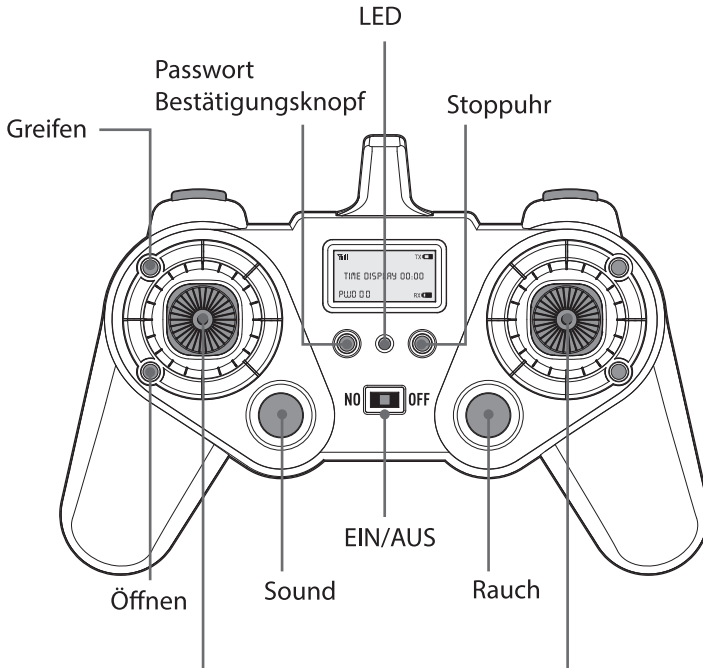

Mittlerer Arm heben

Arm senken

Plattform links drehen



Plattform rechts drehen

Greifer hebt sich



Greifer senkt sich

Mittlerer Arm senken

Arm heben

links vorwärts

rechts vorwärts

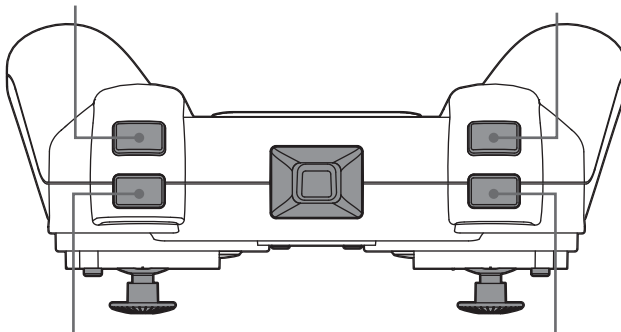

rückwärts links

rückwärts rechts

Einsetzen des Akkus

Öffnen Sie den Deckel mit der Verschlusskappe (Pfeil), setzen Sie den Akku wie im Bild gezeigt ein. Schliessen Sie den Deckel wieder.

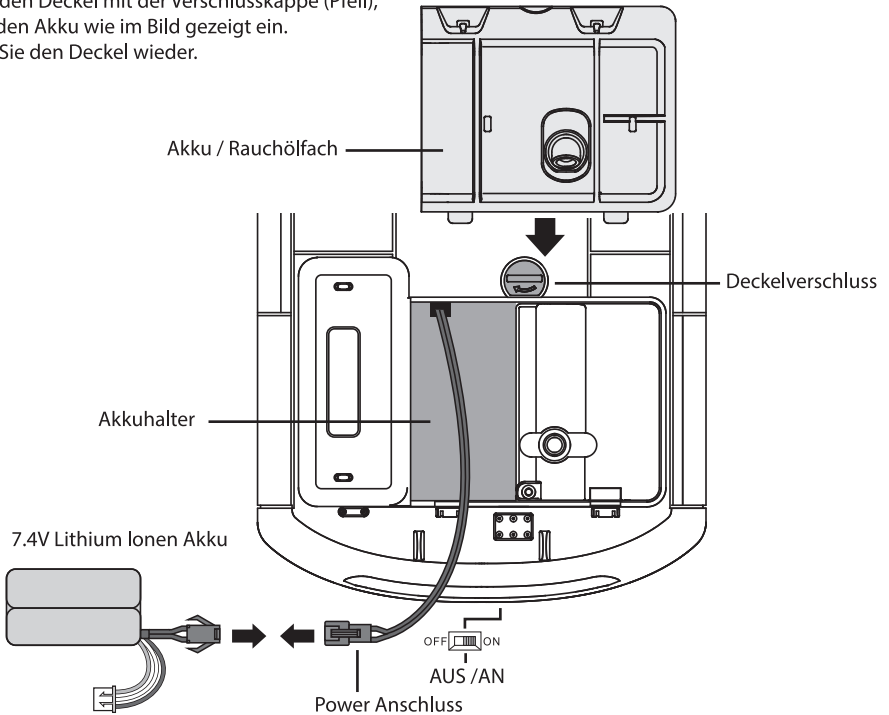

Fernsteuerung - Batterien

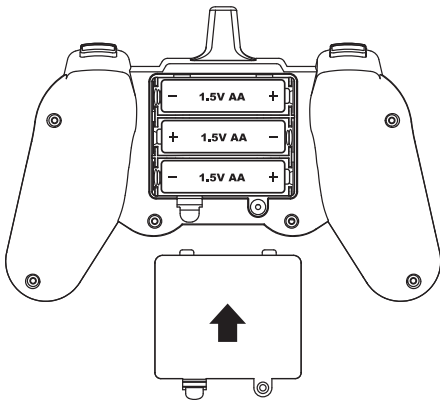

Lasche
nach vorne drücken
zum Öffnen

Sie benötigen 3x 1.5V Batterien.
Lösen Sie die Schraube des Deckels mit einem Schraubendreher. Drücken Sie die Lasche links unten im Bild um den Deckel zu öffnen.
Setzen Sie die Batterien wie gezeigt, mit korrekter Polarität ein.
Verschließen Sie den Deckel und verschrauben Sie ihn wieder.

Bei Nichtbenutzung für längere Zeit: Batterien unbedingt entnehmen!
Versuchen Sie nicht nicht aufladbare Batterien zu laden!

Laden des Akkus

Lademethode

Stecken Sie den USB-Stecker des Ladekabels in einen USB 5V Anschluss. Stecken Sie den weißen Akkustecker in die weiße Ladekabelbuchse.

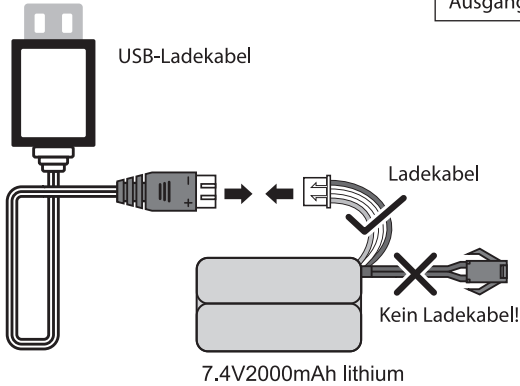

Akku / USB Daten

Akku Daten: 18650 Zellen
7.4V 2000mAh LITHIUM

SMART USB Laderegler mit Überladeschutz
Eingang: 5V 1-2A
Ausgang: 4.2V 800mAh x2

USB Status (Ladevorgang):

Rotes Licht leuchtet dauerhaft, grünes Licht blinkt.

Ist der Akku voll, erlischt das grüne Licht.

Ladezeit: ca. 3-4 Stunden

Stecken Sie den Akku nach dem Ladevorgang vom Ladekabel ab.

Lipo Sicherheitshinweise

Modell Einschaltreihenfolge

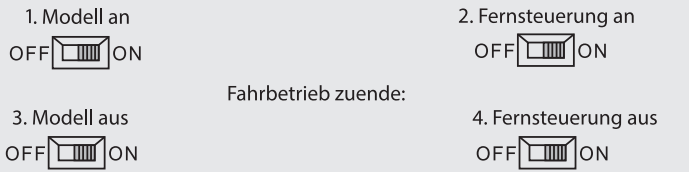

Das Display zeigt den Startbildschirm, 00 blinkt. Sie können nun fahren.

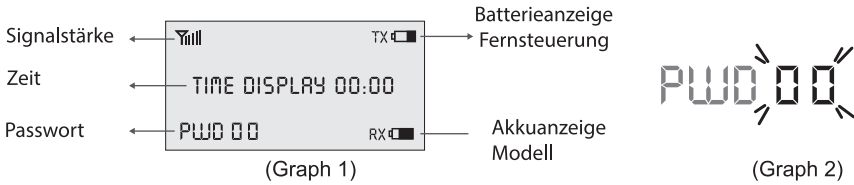

Dieser Bagger hat 2 Betriebsmodi, im 2. Modus kann der Spielbetrieb sobald der Timer abläuft erst nach erneuter Passwordeingabe aufgenommen werden.

Passwort setzen

1. Drücken Sie die Passworttaste (1) für 3 Sekunden.

(Graph 1)

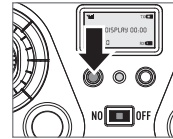

Mit dem rechten Steuerknüppel nach links wählen Sie die Ziffer. Bewegen Sie den Knüppel hoch oder runter um die Zahlen zu ändern.

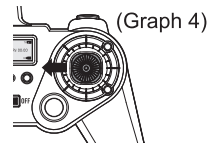
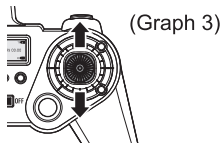
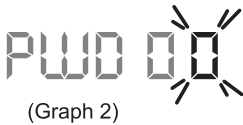

Haben Sie die letzte Ziffer geändert, drücken Sie die Passworttaste zum Speichern.

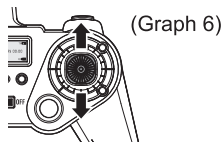
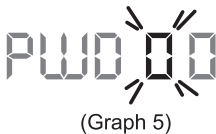

Spielzeiteinstellung

1. Drücken Sie die Taste 3 Sekunden lang um in den Zeitmodus zu gelangen (1)

(Graph 1)

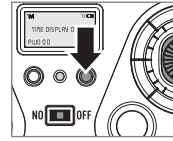

2. Die Minutenanzeige blinkt (2), mit dem rechten Joystick -> Knüppel nach rechts (4), wählen Sie die Sekunden. Joystick (3) nach oben / unten ändert den Zahlen Wert. Bewegen Sie den rechten Joystick nach links, können Sie die Minuten einstellen.

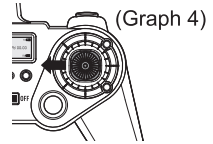
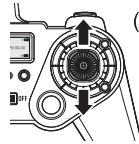

3. Sobald Sie die letzte Ziffer eingegeben haben, drücken Sie die in Abbildung 7 gezeigte Taste um den Wert zu speichern.

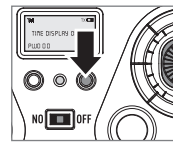
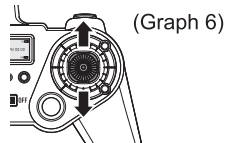

(Graph 7)

Der Countdown zählt nun herunter, in den letzten Sekunden ertönt eine Meldung. Ist der Countdown abgelaufen, geben Sie das Passwort ein und Sie können erneut starten.

Passwort zurücksetzen

Drücken Sie die beiden Tasten für 3 Sekunden gleichzeitig um das Passwort auf 00 zurückzusetzen.

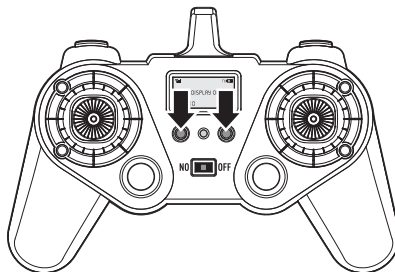

Steuerung Schaufel/ Arm/ Plattform

Schaufel senkt sich

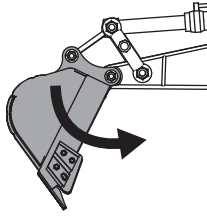
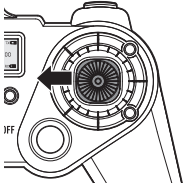

Schaufel hebt sich

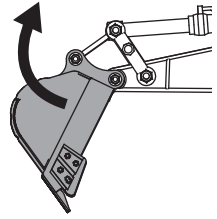
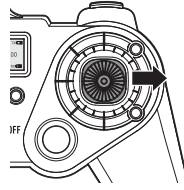

Der mittlere Arm hebt sich

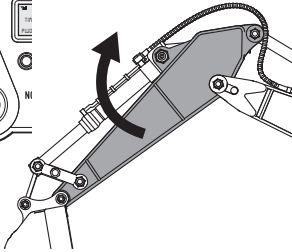
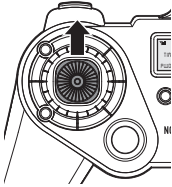

Der mittlere Arm senkt sich

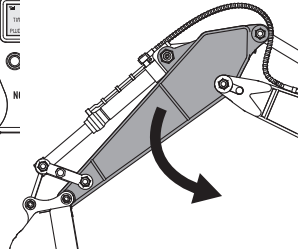
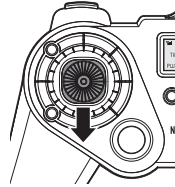

Arm heben

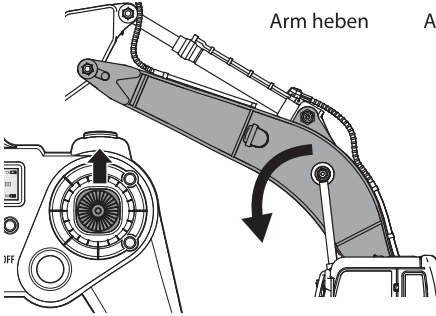

Arm senken

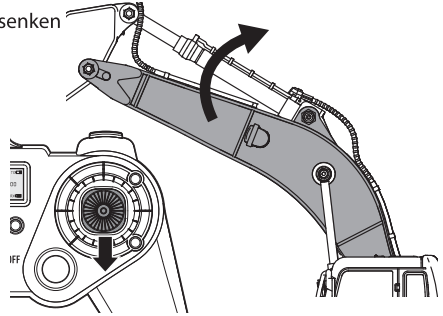

Plattform links drehen

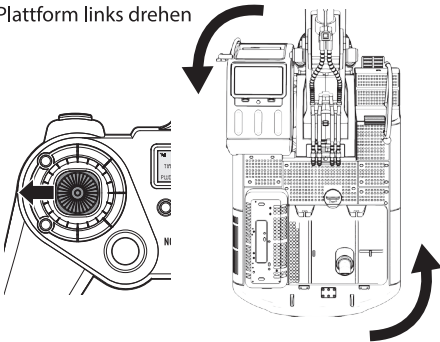

Plattform rechts drehen

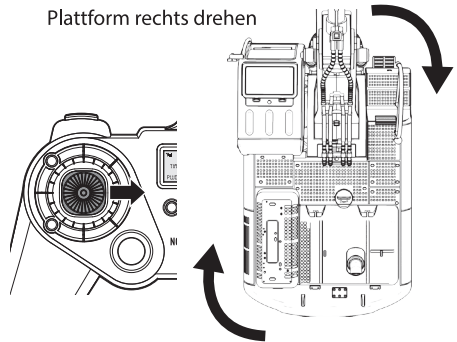

Fahrfunktionen

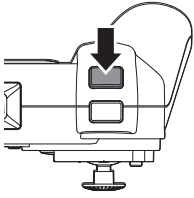

links

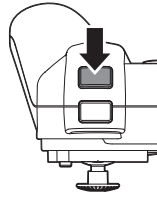
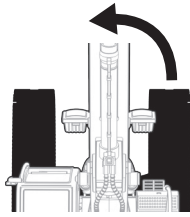

rechts

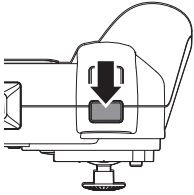
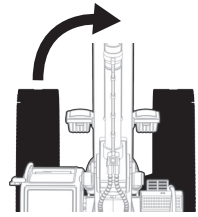

rückwärts links

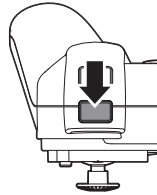
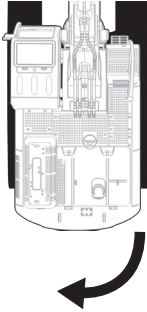

rückwärts rechts

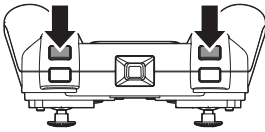

vorwärts

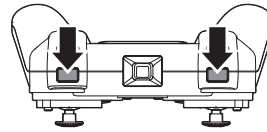
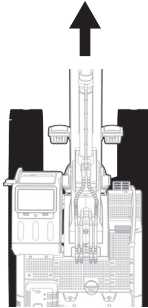

rückwärts

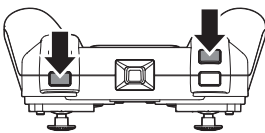
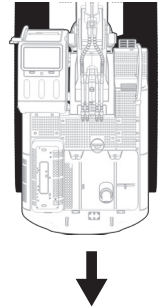

360 Grad Drehung links
(lange drücken)

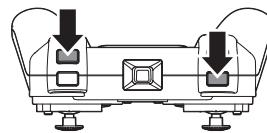
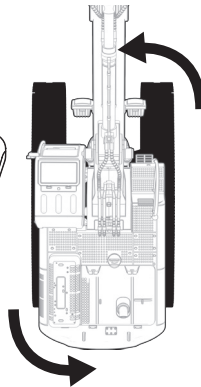

360 Grad Drehung rechts
(lange drücken)

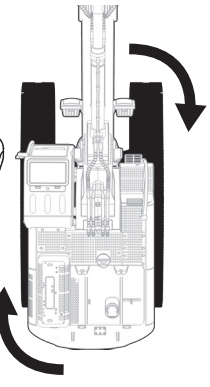

Licht und Soundfunktionen

Drücken Sie den Knopf um das Licht ein- oder auszuschalten.

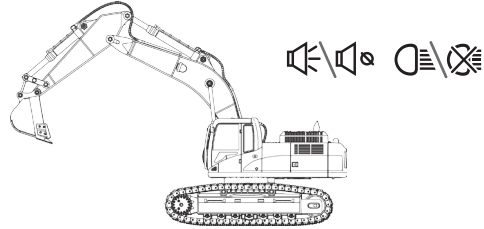
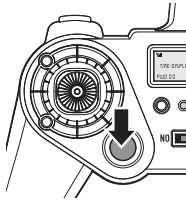

Rauchfunktion

Drücken Sie den Knopf um die Rauchfunktion ein- oder auszuschalten.

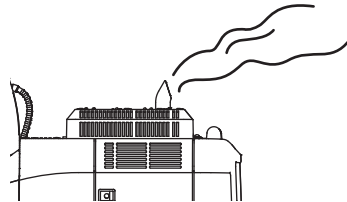
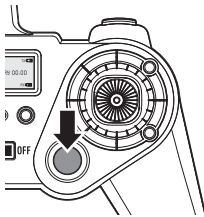

Rauchöl nachfüllen

Öffnen Sie die hintere Abdeckung und füllen Sie ca. 2ml Rauchöl in die Öffnung des Rauchgenerators. Falls Sie einmal versehentlich zu viel ÖL einfüllen müssen Sie das Gehäuse öffnen und den Rauchdraht trocknen.

Achtung!

Niemals mehr als 4-5 Tropfen Rauchöl einfüllen.



Achtung

Gelangt versehentlich Rauchöl in Ihre Augen, waschen Sie diese sofort aus und suchen Sie einen Arzt auf.

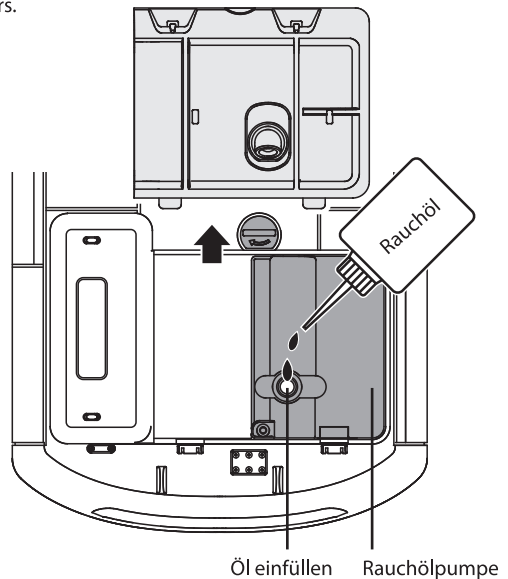

Zubehör auswechseln

1. Entfernen Sie die Schraube (1) und entfernen Sie die Schaufel (2).

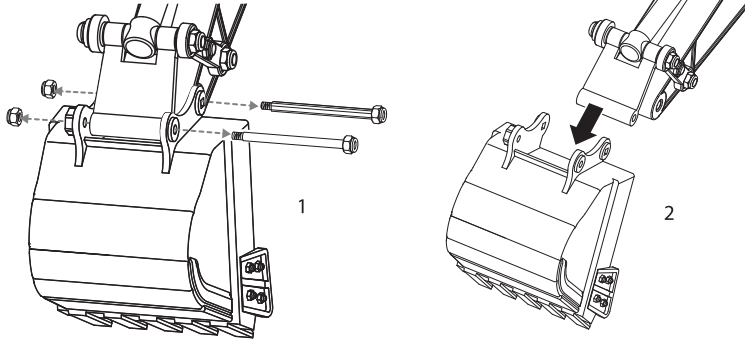

Setzen Sie den Greifer / Hammer wie gezeigt ein und montieren Sie die Schrauben.

im Arm

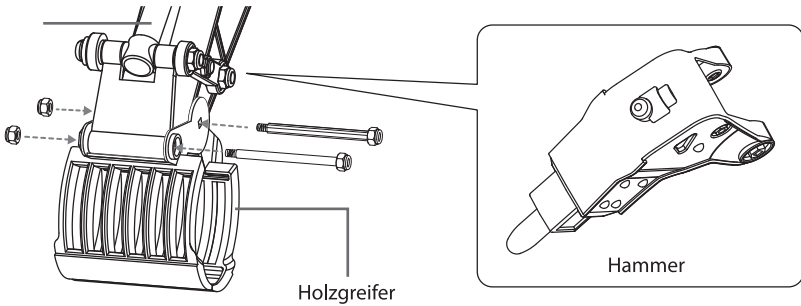

Funktionen des Zubehörs

Hämmern

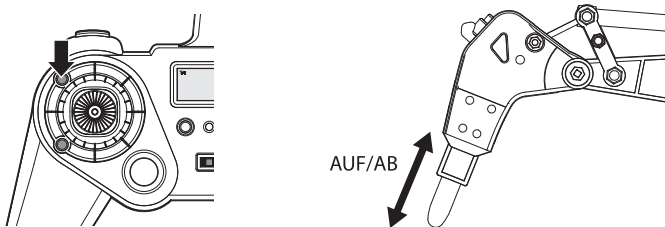

Holz greifen

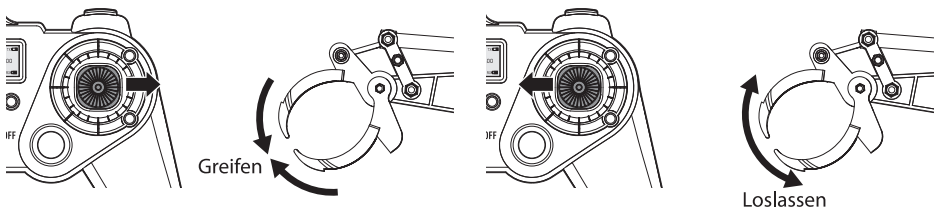

Welcome !

AMEWI TRADE e.K.

Is a young, fresh, international Import and Wholesale company in the RC and Toy industry located in Paderborn.

Our product range contains over 6000 articles.

Containing to it are Cars, Helicopters, Quadrocopters, Boats and Tanks including a lot of extra parts and all needed spare parts.

Our distribution network contains over 600 specialist dealers and online shops.



AMEWI Trade e.K. is an Wholesale Company.
We only distribute our goods to retailers.

IF you are an End-Customer who is buying AMEWI-Products , you contract with your retailer.

In case of warranty please always contact your retailer.

This model is not a toy. It is not suitable for persons below aged 14. Please read the manual –really read it please ! As beginner, please search the help of an experienced RC Modeler to help you on first usage.

This model and its parts have to be kept away from children aged 3 years and below. Single parts could be swallowed and cause danger of suffocation.

Declaration of Conformity

This product has been manufactured according to actual technical standards. The product is matching the requirements of the existing European and national guidelines. The Declaration of Conformity has been proofed. AMEWI Trade e.K. declares that this product is matching the basic requirements and remaining regulations of the guideline 2014/53/EU (RED). The declarations and documents are stored at the manufacturer and can be requested and applied there.

The full text of the declaration of conformity can be found at: <https://amewi.com/de/downloads/index/search/>

For additional questions to the product and conformity please contact:

AMEWI Trade e.K., Nikolaus-Otto-Str. 18, DE-33178 Borcheln, Fax: +49 (0)5251 / 288965-19, Email: info@amewi.com.



Security and Hazard Warnings



Attention! For damage, caused by disregarding of the manual, warranty expires !

We are not liable for secondary failures, material or personal damage, caused by improper usage or disregarding the security notices.

Attention! Based on security and registration (CE) reasons, it is forbidden to modify the product personally. Do not disassemble the product.

Attention! Small parts. Danger of suffocation or risk of injury caused by small parts.

Attention! Suitable for people aged 14+ !



The product is not allowed to get moist or wet. The product is only allowed to be used on flat and clean surfaces. Even a drop down from a small height can cause damage to the product. Usage of more than one Products of same Frequency at the same time is not possible, because it will affect each other.

Battery Notice and Battery Disposal



Attention! Battery do not belong in childrens hands. A change of the battery has to be done by an adult person. Never mix chargeable batteries with non-chargeable batteries. Never mix fully charged batteries with almost empty batteries. Never mix batteries of different capacities. Never try to charge dry batteries. Take care of the correct polarity. Defective batteries belong to special waste. Never leave a charging battery unattended. For questions about the charging time please read the manual or ask the manufacturer.

Disposal



The company AMEWI is registered below the WEEE Reg. Nr. DE93834722 at the foundation EAR and recycles all used electronic parts properly. Electric and electronical products are not allowed to put in household garbage. Please dispose the product at the end of the lifetime according to the actual laws. You as a customer are responsible by law for the return of all used batteries, a disposal over the household garbage is forbidden !

Batteries containing hazardous substances are marked with the alongside symbols, which point to the prohibition of disposal in household garbage.

Additional notations for the critical heavy metal are: Cd=Cadmium, Hg=Quecksilver, Pb=lead (Label is placed on the batteries, for example below the bottom left trash symbols).



Based on RoHS labeling the manufacturer confirms, that all limit values were taken care of at the time of manufacturing.



Batteries labeled with the recycling symbol can be put into used battery collecting tank.

(Most supermarkets have)

They are not allowed to be put into local household garbage.



AMEWI Trade e.K. is involved in the dual system for boxing over the company Firma Landbell AG.

All used boxes are collected from partner companies (waste disposal contractor) at private customers (local household), sorted and properly utilized. The Involvement in a Dual Systems helps to save CO² Emissions.

Remote Control Transmitter Operation

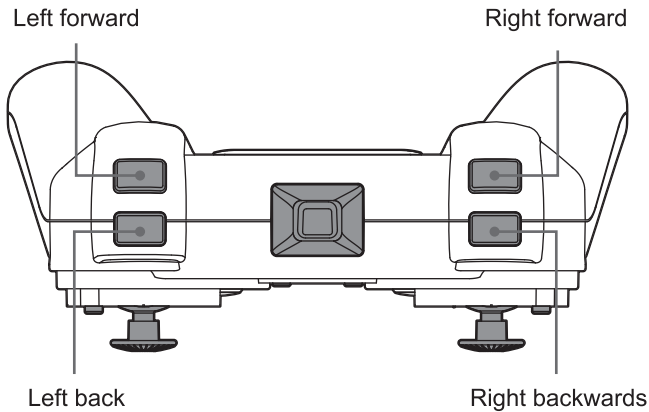
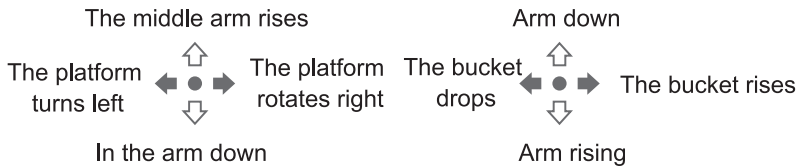
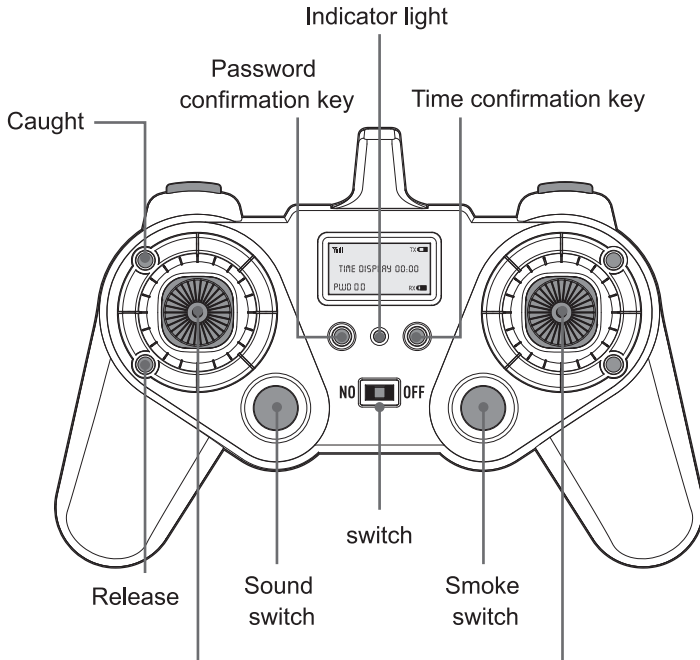

Remote control model battery installation

Model using 7.4V2000mAh lithium battery (battery included) first twist the lock to open the battery cover, refer to the method shown. Do connect the battery into the battery compartment. Close the battery cover and twist the lock.

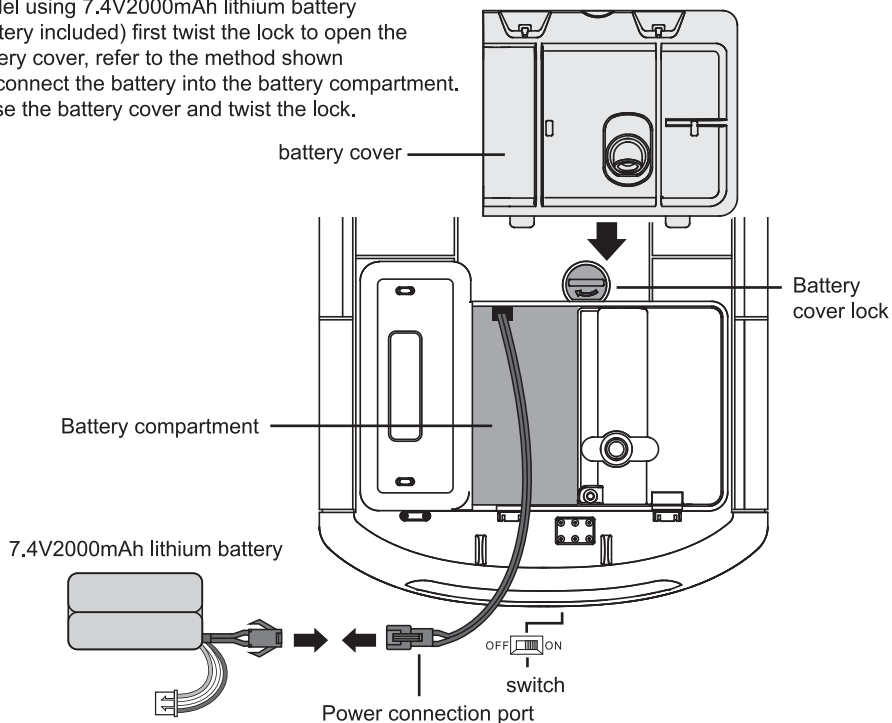

Remote control battery installed

Remote control Use the 3 "1.5V" AA "non-rechargeable battery (battery separately) to open the battery cover and press the correct polarity into the bottom of the remote control battery box. Cover the battery cover and tighten the screws.

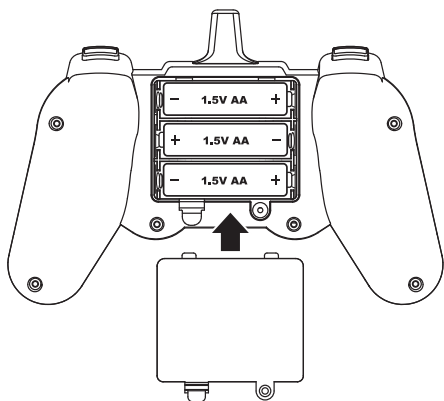

Battery safe instructions:

1. Remove and place the battery in the correct way;
2. Non-rechargeable batteries can not be charged;
3. Rechargeable batteries can only be charged under the supervision of adults;
4. different types of batteries or old and new batteries can not be mixed;
5. The same or the same model with the recommended model of the battery can be used;
6. The rechargeable battery should be removed from the model before charging;
7. The battery is placed in the correct polarity;
8. The exhausted battery should be removed from the model;
9. The power terminals must not be shorted;

Battery charging instructions

Charging method

Connect the white port of the lithium battery to the USB charging port as shown and ensure that the port is tight and correct, and then plug the USB charging head into the power adapter to charge it.

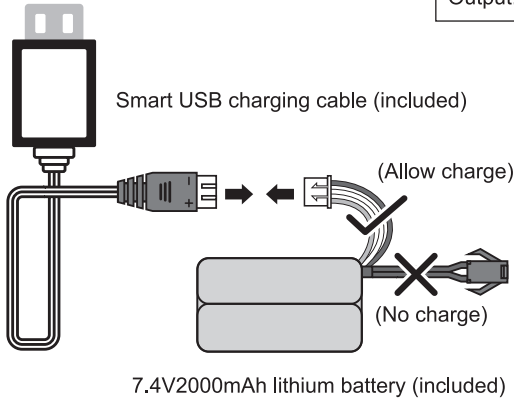

Battery / USB parameters

Battery Specifications: 18650
7.4V2000mAh lithium battery

Smart USB balanced with overcharge protection
Input: 5.0V 1-2A
Output: 4.2V 800mAh X2

USB status when charging:

When not charging, the indicator light is on
When charging the indicator light -
red light is always on + green light flash
When the battery is full, the light is on

Charging time: 3-4 hours
When the battery charge is complete,
please unplug it
USB charging cable.

Lithium battery battery precautions

1. Only use the original configuration USB charging cable to charge the battery;
2. Must use the white big head interface to charge, black head can not be used to charge;
3. 7.4-volt lithium battery must use 5-volt USB charging head;
4. The appearance of the damage can not be recharged, damaged lithium battery charging occurs when the spontaneous combustion caused by fire.
5. Lithium battery charging, be sure to put in the iron box charge;
6. The battery can not be placed over the approved charging time;

Lithium battery safe instructions

- Lithium batteries are more dangerous than other batteries, be sure to use the battery before use, the company is not responsible for any damage caused by improper use.
 - Do not use the charger other than the original to charge, so as to avoid the risk of explosion fire.
 - Do not impact, disassemble, positive and negative reverse, burn the battery, avoid metal objects touch the battery positive and negative caused by short circuit, and please prevent sharp items piercing the battery to avoid the risk of battery fire.
- Be careful when charging, to ensure that within your line of sight within the charge, and away from the children can be exposed to the place in case of danger, if the battery after the use of deterioration, is strictly prohibited, otherwise it will cause the battery expansion, deformation, explosion or even fire burning, The safety of life and property.
- Waste batteries, please strictly in accordance with national or regional waste disposal laws and regulations to avoid pollution of the environment.

Remote control frequency matching and boot

1. This product uses 2.4GHz frequency remote control. The user first use the operation, first model and remote control to install the battery to ensure that power, turn on the power, boot automatically on the frequency, and have issued on the frequency of sound, "drop" on the frequency to complete.

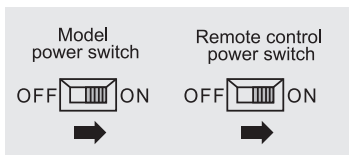

2. The display shows the start screen (Graph 1). The password "00" flashes (Graph 2), and you can enter the play mode directly.

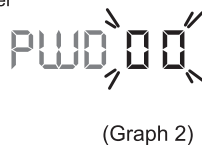
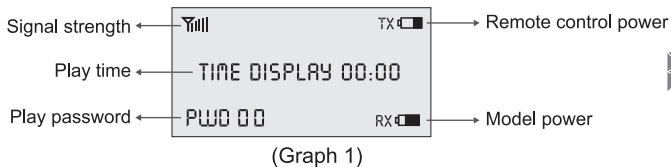

- This product has two play modes:
1. boot mode
 2. Encrypt the play mode

Remote control password setting

1. Press and hold the password key for three seconds (Graph 1) to enter the setup password mode.

(Graph 1)

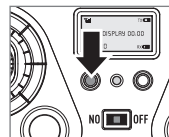

2. At this time, bit "0" flashes (Graph 2). On the right joystick, (password switch from 0-9) right keeper (password switch from 0-9) (Graph 3). After selecting the number, the right joystick is pushed directly to the left (Graph 4) to set the tens digit password, and the right bar can be pushed back to the number of digits.

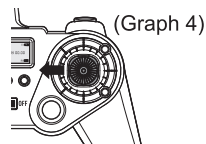
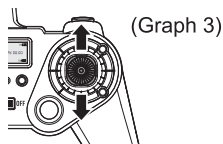

3. Right forward rod directly to the left after the push, the ten "0" flashing (Graph 5), right-hand bar (password from 0-9 switch) righthair (Password switch from 9-0) (Graph 6), press the password confirmation key (Graph 1) to complete the password settings. The display shows this pattern, and "*" (Graph 7) does not flash. Flashing.

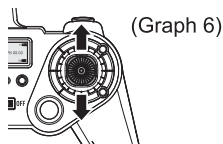

Play time setting

1. Press and hold the time confirmation key for three seconds (Graph 1), enter the set time mode,

(Graph 1)

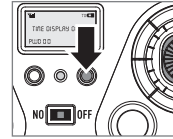

2. At this time, the number of digits per minute is flashing (Graph 2), and the right joystick (switch from 0-9) to the right shunt (switch from 0-9) (Graph 3). After selecting the number two seconds, the right joystick is pushed directly to the left (Graph 4). Set the time minutes to ten digits.



(Graph 2)

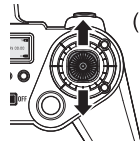

(Graph 3)

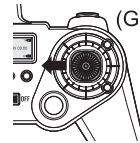

(Graph 4)

3. At this time, the display time min 10 digit "0" flashes (Graph 5), (time is switched from 0-9) Righthair (switch from 0-9) (Graph 6). After selecting the number, press the time confirmation key (Graph 7) to complete the time setting.



(Graph 5)

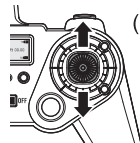

(Graph 6)

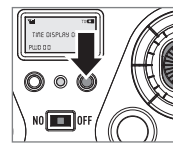

(Graph 7)

When the time setting is complete, the display shows that the time countdown starts counting and can be played anytime. When the play time to the last 10 seconds the receiver will have issued a "drip" alarm, until the time to the receiver to stop working, "drop" alarm sound also stopped. Wait for the remote control to enter the password and time settings again to continue playing.

Reset Password

While long press the password to confirm the key + time to confirm the key 3 seconds to clear the original old password. Restore the initial password "00" to reset the new password.

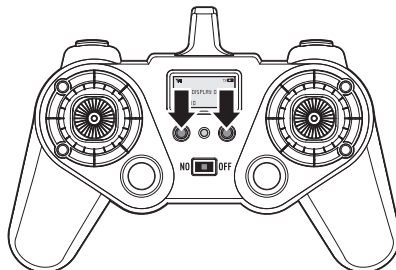

Mining arm and platform control

The bucket drops

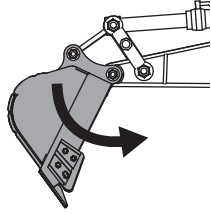
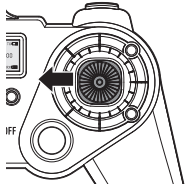

The bucket rises

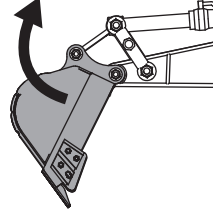
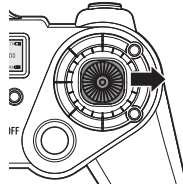

The middle arm rises

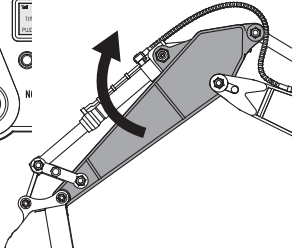
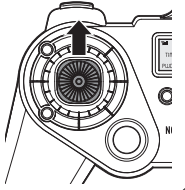

In the arm down

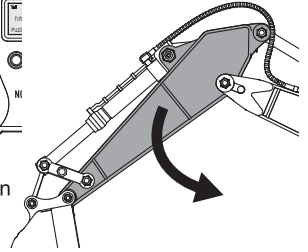
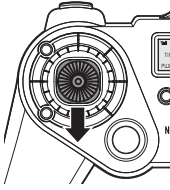

Arm down

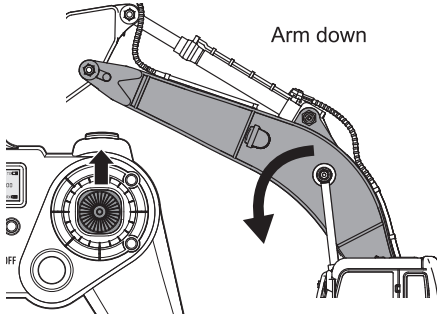

Arm rising

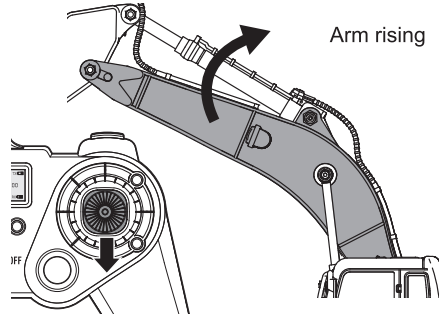

The platform turns left

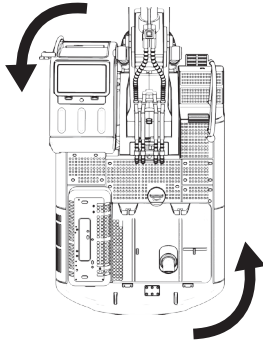
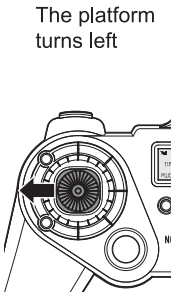

The platform rotates right

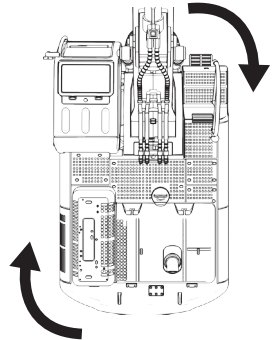
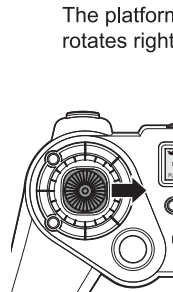

Model driving control

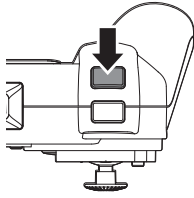

Turn left

[Long press left forward rotation]

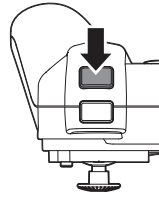
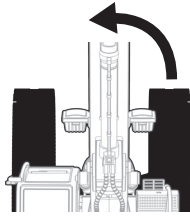

Turn right

[Long press the right forward rotation]

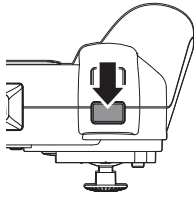
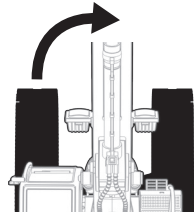

Left back

[Long press left back rotation]

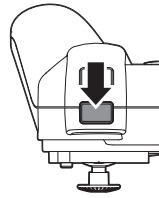
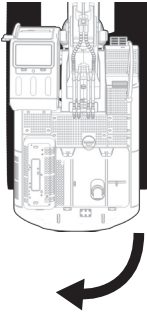

Right backwards

[Long press back right]

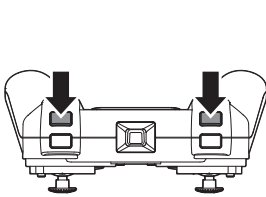
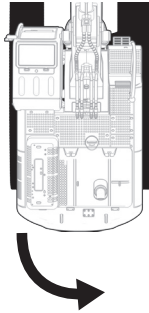

go ahead

[While long press]

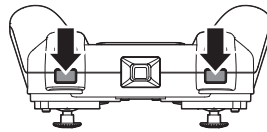
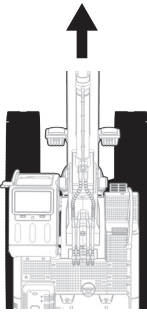

Backwards

[While long press]

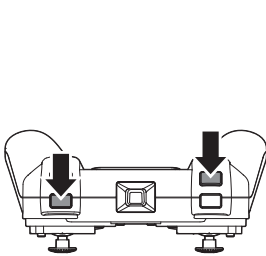
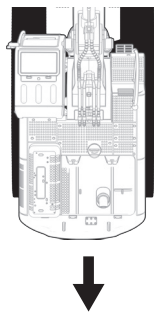

In situ left 306 degrees rotation

[While long press]

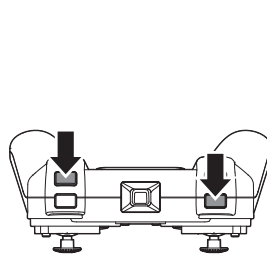
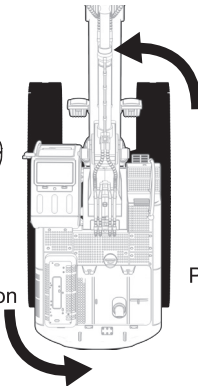

Place right 306 degrees rotation

[While long press]

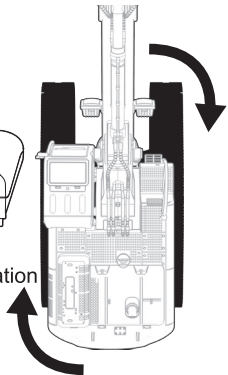

Lighting and sound control

After the model starts with lights and sound, press the sound key to turn off the sound and light at the same time, then press it to open.

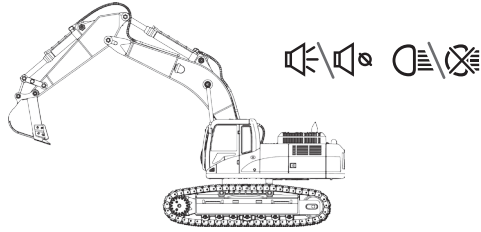
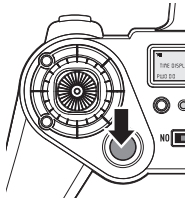

About smoke

After the model starts in the play project, press the smoke button to open the smoke function, then press it to close.

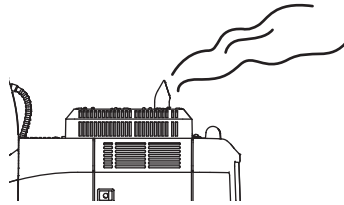
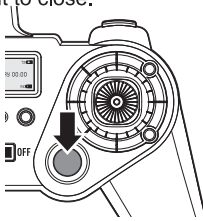

About adding smoke to smoke

ATTENTION

Not add more, about 4-5 drop
Do not join too much!

! WARNING

"Smoke oil" is strictly prohibited!
If you accidentally drip into the
eyes, please rinse with water,
and timely medical treatment!

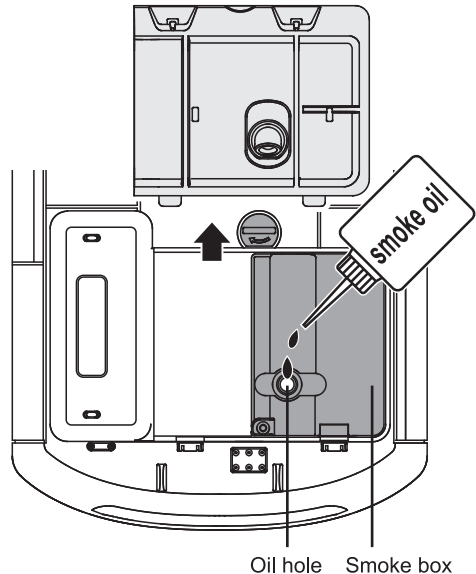

Accessories replacement

1. Remove the bucket fixing screw (Graph 1) and remove the bucket (Graph 2).

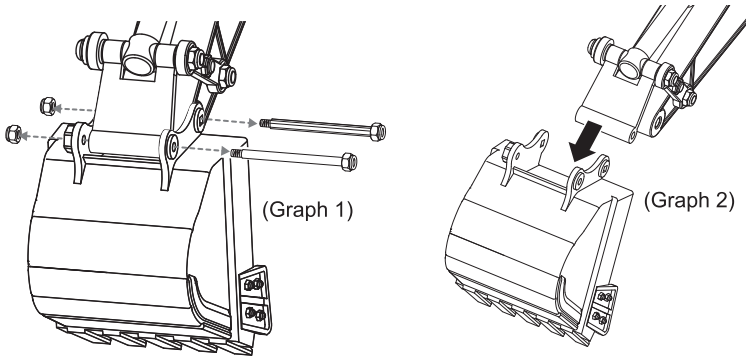

2. Attach the fitting to the center arm and insert the screw on the nut to tighten (Graph 1) (the mounting method is the same).

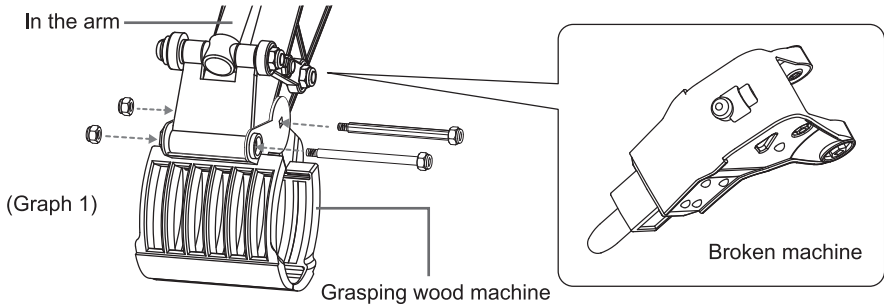

The control of the accessories

Broken machine

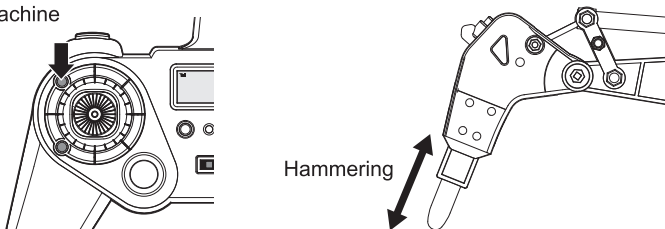

Grasping wood machine

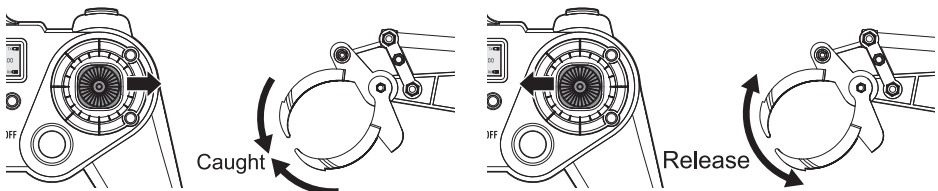

CE